



# FOCUS LCDs

LCDs MADE SIMPLE<sup>®</sup>



ISO 9001

QUALITY  
MANAGEMENT

MEDICAL | INDUSTRIAL | DEFENSE | AGRICULTURE | FOOD SERVICE

## E21RA-I-XW1000-N

### Product Description

- |   |   |
|---|---|
| <ul style="list-style-type: none"><li>• 2.1-inch TFT (56.18x59.71mm)</li><li>• 480x480 Pixels</li><li>• SPI+16/18/24-Bit RGB Interfaces</li><li>• Wide Temperature Range</li><li>• All Viewing Angles</li></ul> | <ul style="list-style-type: none"><li>• IPS, Transmissive</li><li>• No Touch panel</li><li>• 1000 NITS</li><li>• TFT IC: ST7701S</li><li>• RoHS Compliant</li></ul> |
|---|---|

**Revision History**

Date	Rev. No	Page	Summary
09/21/2023	1.0	All	First issue

## Description

This is a color active matrix TFT (Thin Film Transistor) LCD (Liquid Crystal Display) that uses amorphous silicon TFT as a switching device. This model is composed of a transmissive type TFT-LCD Panel, driver circuit, and backlight unit. The resolution of the 2.1" TFT-LCD contains 480x480 pixels and can display up to 16.7M colors.

## Features

Input Voltage: 2.8V

TFT Interface: SPI+16/18/24-bit RGB

General Information Items	Specification	Unit	Note
	Main Panel		
TFT Display Area (AA)	53.28(H) x 53.28(V) (2.1 inch)	mm	--
Driver Element	TFT active matrix	--	--
Display Colors	16.7M	colors	--
Number of Pixels	480(RGB)x480	dots	--
TFT Pixel Arrangement	RGB vertical stripe	--	--
Pixel Pitch	0.111(H) x 0.111 (V)	mm	--
Viewing Angle	ALL	o'clock	--
TFT Controller IC	ST7701S	--	--
Display Mode	Transmissive/Normally Black	--	--
Operating Temperature	-20 to +70	°C	--
Storage Temperature	-30 to +80	°C	--

## Mechanical Information

Item		Min.	Typ.	Max.	Unit	Note
Module Size	Horizontal (H)	--	56.18	--	mm	--
	Vertical (V)	--	59.71	--	mm	--
	Depth (D)	--	2.24	--	mm	--
Weight		--	12	--	g	Approximate

## 1. Outline Dimensions

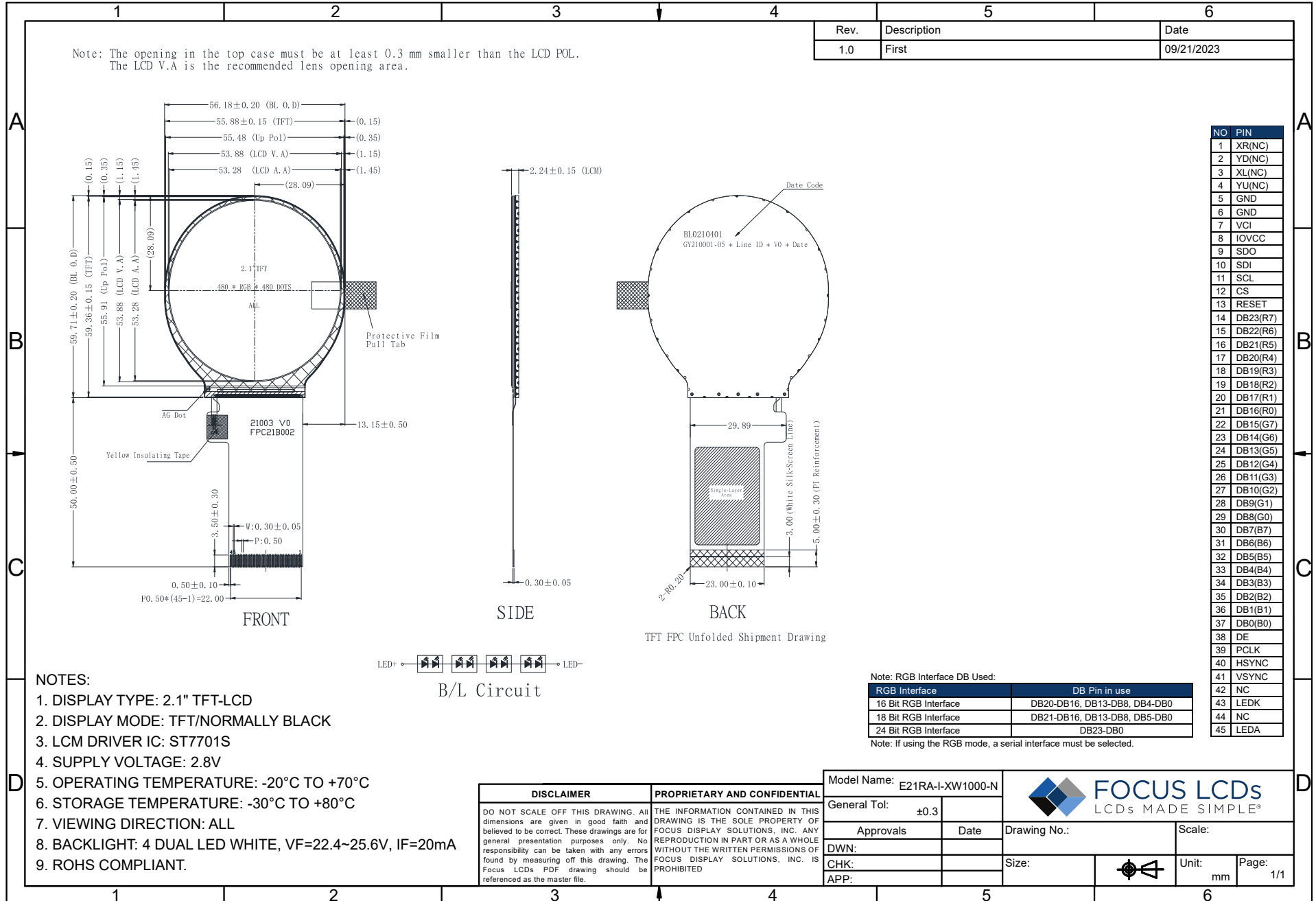

## 2. Block Diagram

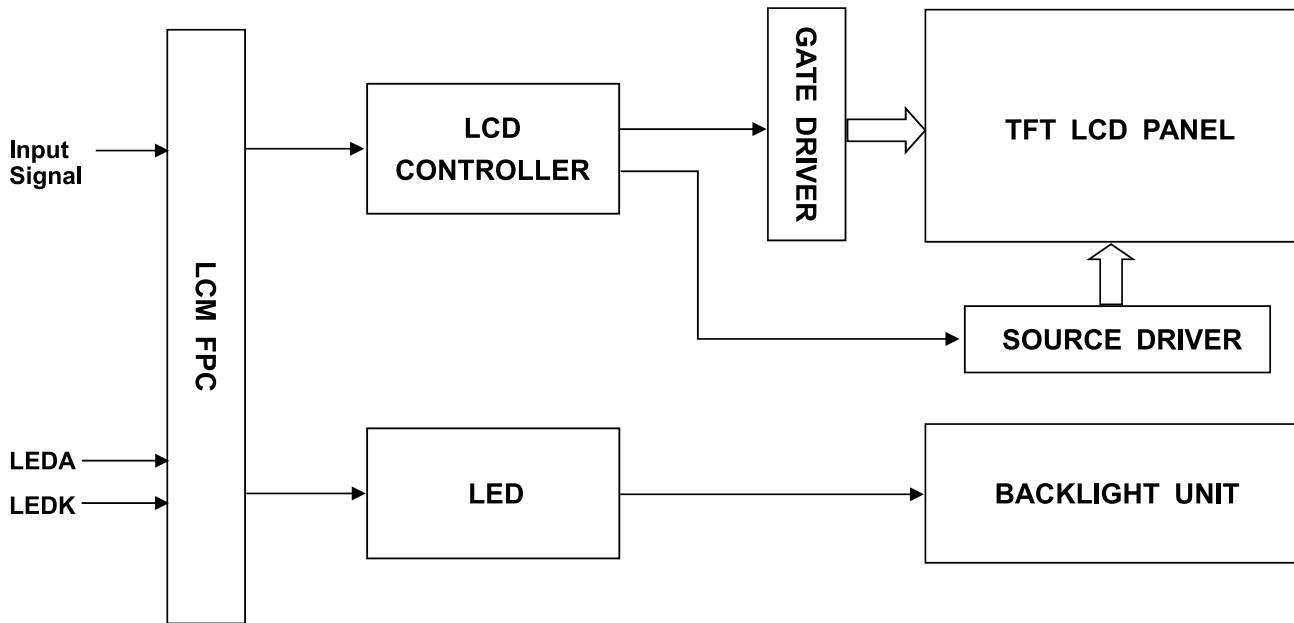

### 3. Input Terminal Pin Assignment

#### 3.1 TFT Pin Assignment

NO.	Symbol	Description	I/O
1	XR(NC)	Touch panel right glass terminal.	--
2	YD(NC)	Touch panel bottom film terminal.	--
3	XL(NC)	Touch panel left glass terminal.	--
4	YU(NC)	Touch panel top film terminal.	--
5	GND	Ground.	P
6	GND	Ground.	P
7	VCI	Supply voltage (3.3V).	P
8	IOVCC	I/O power supply voltage.	P
9	SDO	SPI interface output pin. The data is output on the falling edge of the SCL signal. If not used, leave this pin open.	O
10	SDI	Data lane in 1 data lane serial interface. The data is latched on the rising edge of the SCL signal.	I
11	SCL	This pin is used to select "data or command" in the parallel interface. When D/CX = '1', data is selected. When D/CX = '0', command is selected. This pin is used serial interface clock in 3-wire 9-bit / 4-wire 8-bit serial data interface. Fix this pin at IOVCC or GND when not in use.	I
12	CS	Chip select input pin ("Low" enable). Fix this pin at IOVCC or GND when not in use.	I
13	RESET	Reset pin. Setting either pin low initializes the LSI. Must be reset after power is supplied.	I
14-37	DB23-DB0	24-bit parallel bi-directional data bus for MCU system and RGB interface mode. Fix to GND level when not in use.	I/O
38	DE	Data enable signal for RGB interface operation. Fix this pin at IOVCC or GND when not in use.	I
39	PCLK	Dot clock signal for RGB interface operation. Fix this pin at IOVCC or GND when not in use.	I
40	HSYNC	Line synchronizing signal for RGB interface operation. Fix this pin at IOVCC or GND when not in use.	I
41	VSYNC	Frame synchronizing signal for RGB interface operation. Fix this pin at IOVCC or GND when not in use.	I
42	NC	No connection.	--
43	LEDK	Cathode pin of backlight.	P
44	NC	No connection.	--
45	LEDA	Anode pin of backlight.	P

## 4. LCD Optical Characteristics

### 4.1 Optical Specifications

Item	Symbol	Condition	Min	Typ.	Max	Unit	Note
Color Gamut	S(%)		--	59.48	--	%	(5)
Contrast Ratio	CR		800	1000	--	%	(2)
Response Time	Rising	$T_R$	--	30	35	ms	(4)
	Falling	$T_F$					
Color Filter Chromaticity	White	$W_X$	$\theta=0$ Normal viewing angle	0.2574	0.2974	0.3374	(5)(6)
		$W_Y$		0.2583	0.2983	0.3383	
	Red	$R_X$		0.5852	0.6252	0.6652	
		$R_Y$		0.3136	0.3536	0.3936	
	Green	$G_X$		0.2937	0.3337	0.3737	
		$G_Y$		0.5352	0.5752	0.6152	
	Blue	$B_X$		0.1071	0.1471	0.1871	
		$B_Y$		0.0314	0.0714	0.1114	
Viewing Angle	Hor.	$\Theta_L$	CR $\geq$ 10	80	85	--	degree
		$\Theta_R$		80	85	--	
	Ver.	$\Theta_T$		80	85	--	
		$\Theta_B$		80	85	--	
Option View Direction			ALL				(1)

#### Measuring Conditions:

1. Dark Room
2. Ambient Temperature of 25 $\pm$ 2 $^{\circ}$ C
3. 15 Minute Warm up

## Optical Specification Reference Notes:

### (1) Definition of Viewing Angle:

The viewing angle is the angle at which the contrast ratio is greater than 10. The viewing angles are determined for the horizontal or 3,9 o'clock direction and the vertical or 6,12 o'clock direction with respect to the optical axis which is normal to the LCD surface.

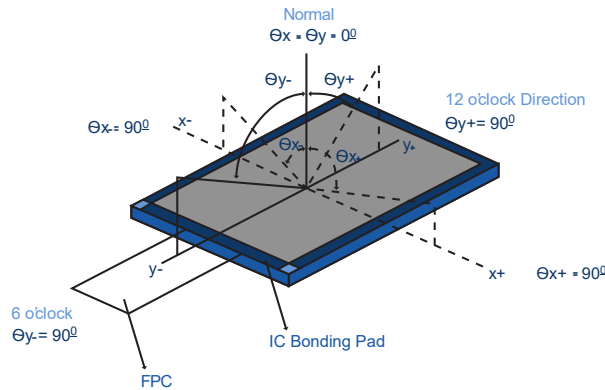

### (2) Definition of Contrast Ratio:

Measured at the center point of panel. The contrast ratio (Cr) measured on a module, is the ratio between the luminance (Lw) in a full white area (R=G=B=1) and the luminance (Ld) in a dark area (R=G=B=0).

$$Cr = \frac{L_w}{L_d}$$

### (3) Definition of Transmittance (T%):

The transmittance of the panel including the polarizers is measured with electrical driving. The equation for transmittance Tr is:

$$Tr = \frac{I_t}{I_o} \times 100\%$$

$I_o$  = the brightness of the light source.

$I_t$  = the brightness after panel transmission

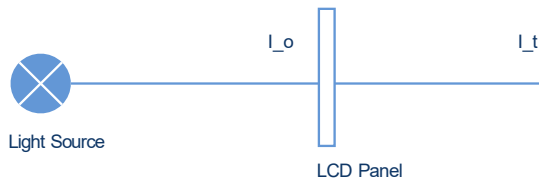

### (4) Definition of Response Time (TR, TF):

The rise time 'Tr' is defined as the time for luminance to change from 90% to 10% as a result of a change of the electrical condition. The fall time 'Tf' is defined as the time for luminance to change from 10% to 90% as a result of a change of the electrical condition.

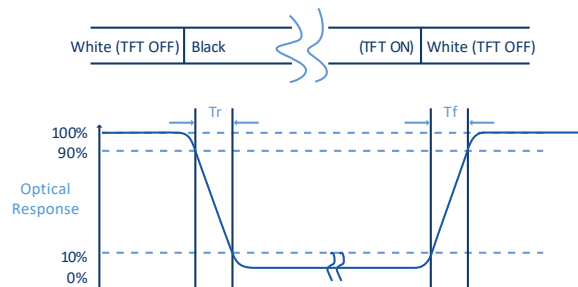

## (5) Definition of Color Gamut:

Measuring machine CFT-01. NTSC's Primaries:  $R(x,y,Y)$ ,  $G(x,y,Y)$ ,  $B(x,y,Y)$ . FPM520 of Westar Display Technologies, INC., which utilized SR-3 for Chromaticity and BM-5A for other optical characteristics. The color chromaticity shall be calculated from the spectral data measured with all pixels first in red, green, blue and white. Measurements shall be made at the center of the panel.

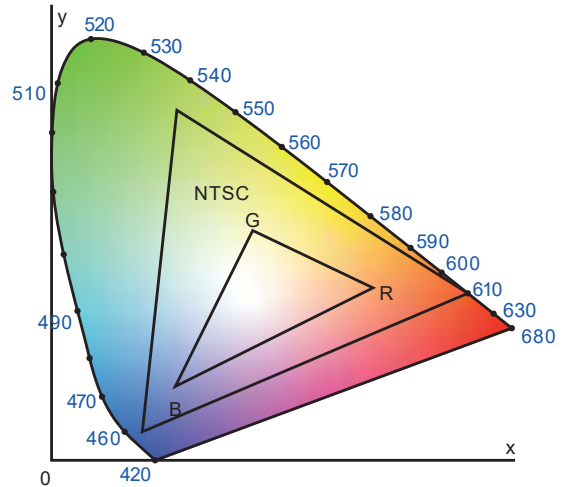
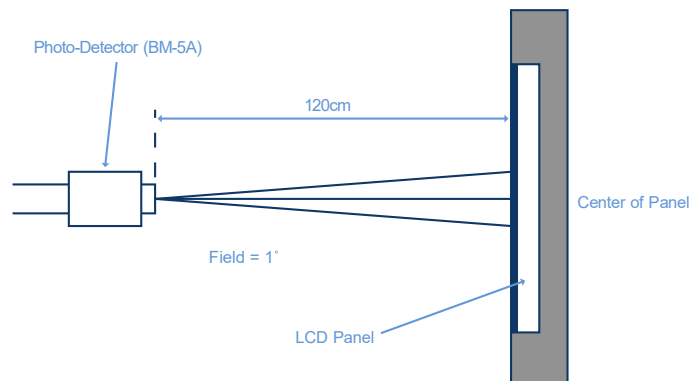
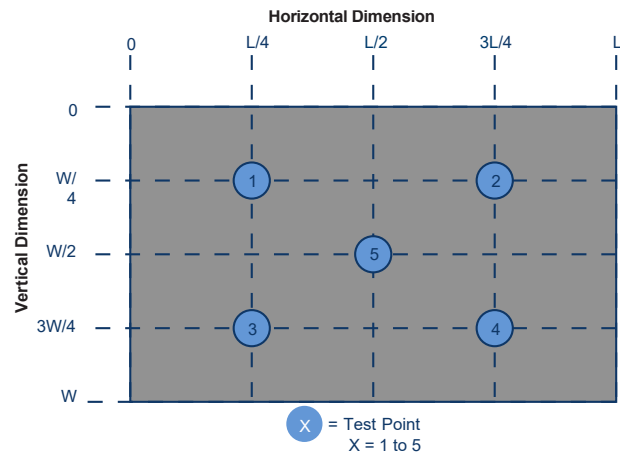
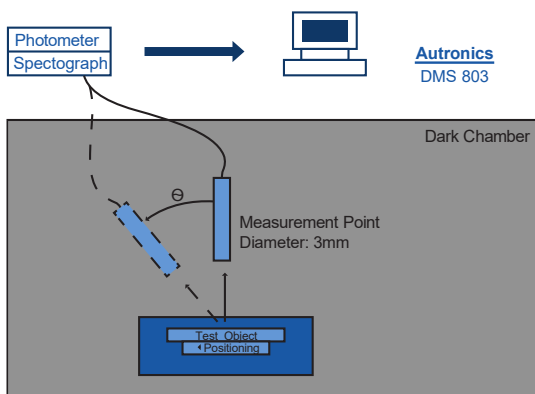

Fig. 1931 CIE Chromaticity Diagram

$$\text{Color Gamut: } S = \frac{\text{Area of RGB Triangle}}{\text{Area of NTSC Triangle}} \times 100\%$$

## (6) Definition of Optical Measurement Setup:

The LCD module should be stabilized at a given temperature for 20 minutes to avoid abrupt temperature change during measuring. In order to stabilize the luminance, the measurement should be executed after lighting backlight for 20 minutes.



## 5. TFT Electrical Characteristics

### 5.1 Absolute Maximum Rating (Ta=25°C, VSS=0V)

Characteristics	Symbol	Min	Max	Unit
Digital Supply Voltage	VDD	-0.3	4.6	V
Supply Voltage (Logic)	IOVCC	-0.3	4.6	V
Operating Temperature	T <sub>OP</sub>	-20	+70	°C
Storage Temperature	T <sub>ST</sub>	-30	+80	°C

*NOTE: If the absolute maximum rating of the above parameters is exceeded, even momentarily, the quality of the product may be degraded. Absolute maximum ratings specify the values which the product may be physically damaged if exceeded. Be sure to use the product within the range of the absolute maximum ratings.*

### 5.2 DC Electrical Characteristics

Characteristics	Symbol	Min	Typ.	Max	Unit	Note
Digital Supply Voltage	VDD/VCI	2.5	2.8	3.6	V	--
Supply Voltage (Logic)	IOVCC	1.65	1.8	3.3	V	--
Normal Mode Current Consumption	IDD	--	19	30	mA	--
Level Input Voltage	V <sub>IH</sub>	0.7*IOVCC	--	IOVCC+0.3	V	--
	V <sub>IL</sub>	GND-0.3	--	0.3*IOVCC	V	--
Level Output Voltage	V <sub>OH</sub>	IOVCC-0.4	--	--	V	--
	V <sub>OL</sub>	GND	--	GND+0.4	V	--

## 5.3 LED Backlight Characteristics

The backlight system is edge lighting type with 4 Dual LED Chips

Item	Symbol	Min	Typ.	Max	Unit	Note
Forward Current	$I_F$	--	20	--	mA	--
Forward Voltage	$V_F$	22.4	24.09	25.6	V	--
LCM Luminance	$L_V$	900	1000	--	cd/m <sup>2</sup>	(3)
LED Lifetime	Hr	--	50000	--	hour	(1)(2)
Uniformity	Avg	80	--	--	%	(3)

**Note 1:** LED lifetime (Hr) can be defined as the time in which it continues to operate under the condition:  $T_a=25 \pm 3^\circ\text{C}$ , typical IL value indicated in the above table until the brightness becomes less than 50%.

**Note 2:** The "LED lifetime" is defined as the module brightness decrease to 50% original brightness at  $T_a=25^\circ\text{C}$  and  $I_F = 20\text{mA}$ . The LED lifetime could be decreased if operating  $I_F$  is larger than 20mA. The constant current driving method is suggested.



**BL CIRCUIT DIAGRAM**

**Note 3:** Luminance Uniformity of these 9 points is defined as below:

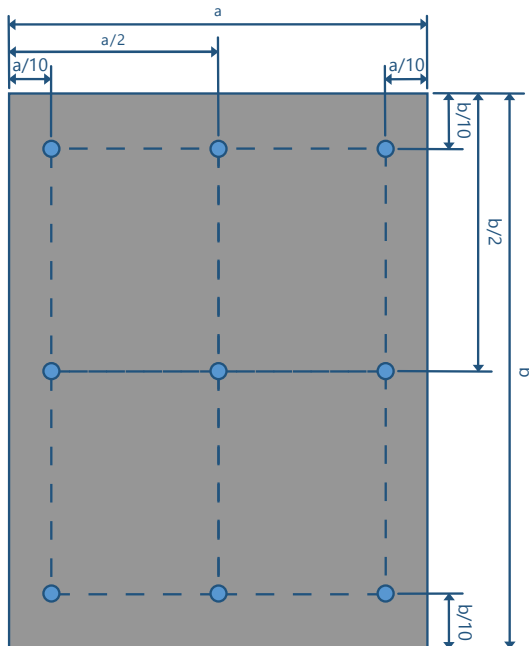

$$\text{Luminance} = \frac{(\text{Total Luminance of 9 Points})}{9}$$

$$\text{Uniformity} = \frac{\text{Minimum Luminance in 9 Points (1-9)}}{\text{Maximum Luminance in 9 Points (1-9)}}$$

## 6. TFT AC Characteristics

### 6.1 High Speed Data Transmission: Data-Clock Timing

For high speed data transmission clock-lane timing diagrams and tables, see page 85 of the data sheet for controller IC ST7701S. The data sheet can be found here:

<https://focuslcds.com/wp-content/uploads/Drivers/ST7701S.pdf>

### 6.2 High Speed Data Transmission

For high speed data transmission diagrams and tables, see page 95 of the data sheet for controller IC ST7701S. The data sheet can be found here:

<https://focuslcds.com/wp-content/uploads/Drivers/ST7701S.pdf>

### 6.3 Turnaround Procedure

For turnaround procedure diagrams and tables, see the second table and diagram on page 99 of the data sheet for controller IC ST7701S. The data sheet can be found here:

<https://focuslcds.com/wp-content/uploads/Drivers/ST7701S.pdf>

### 6.4 Switching the Clock Lane Between Clock Transmission and Low-Power Mode

For switching the clock lane between clock transmission and low-power mode tables and diagrams, see page 81 of the data sheet for controller IC ST7701S. The data sheet can be found here:

<https://focuslcds.com/wp-content/uploads/Drivers/ST7701S.pdf>

### 6.5 Reset Timing Characteristics

For the reset timing characteristics table and diagram, see page 54 for the data sheet for controller IC ST7701S. The data sheet can be found here:

<https://focuslcds.com/wp-content/uploads/Drivers/ST7701S.pdf>

## 7. Quality Inspection Standards

For TFT quality inspection standards, please see the following link:

<https://focuslcds.com/lcd-resources/tft-quality-inspection-standards/>

## 8. Cautions and Handling Precautions

### 8.1 Handling and Operating the Module

1. When the module is assembled, it should be attached to the system firmly. Do not warp or twist the module during assembly work.
2. Protect the module from physical shock or any force. In addition to damage, this may cause improper operation or damage to the module and back-light unit.
3. Note that polarizer is very fragile and could be easily damaged. Do not press or scratch the surface.
4. Do not allow drops of water or chemicals to remain on the display surface. If you have the droplets for a long time, staining and discoloration may occur.
5. If the surface of the polarizer is dirty, clean it using some absorbent cotton or soft cloth.
6. The desirable cleaners are water, IPA (Isopropyl Alcohol) or Hexane. Do not use ketene type materials (ex. Acetone), Ethyl alcohol, Toluene, Ethyl acid or Methyl chloride. It might permanent damage to the polarizer due to chemical reaction.
7. If the liquid crystal material leaks from the panel, it should be kept away from the eyes or mouth. In case of contact with hands, legs, or clothes, it must be washed away thoroughly with soap.
8. Protect the module from static; it may cause damage to the CMOS ICs.
9. Use fingerstalls with soft gloves in order to keep display clean during the incoming inspection and assembly process.
10. Do not disassemble the module.
11. Protection film for polarizer on the module shall be slowly peeled off just before use so that the electrostatic charge can be minimized.
12. Pins of I/F connector shall not be touched directly with bare hands.
13. Do not connect, disconnect the module in the "Power ON" condition.
14. Power supply should always be turned on/off by the item Power On Sequence & Power Off Sequence.

### 8.2 Storage and Transportation

1. Do not leave the panel in high temperature, and high humidity for a long time. It is highly recommended to store the module with temperature from 0 to 35°C and relative humidity of less than 70%.
2. Do not store the TFT-LCD module in direct sunlight.
3. The module shall be stored in a dark place. When storing the modules for a long time, be sure to adopt effective measures for protecting the modules from strong ultraviolet radiation, sunlight, or fluorescent light.
4. It is recommended that the modules should be stored under a condition where no condensation is allowed. Formation of dewdrops may cause an abnormal operation or a failure of the module. In particular, the greatest possible care should be taken to prevent any module from being operated where condensation has occurred inside.
5. This panel has its circuitry FPC on the bottom side and should be handled carefully in order not to be stressed.