



FOCUS LCDs

LCDs MADE SIMPLE[®]



ISO 9001

QUALITY
MANAGEMENT

MEDICAL | INDUSTRIAL | DEFENSE | AGRICULTURE | FOOD SERVICE

E23GA-CW320-N

Product Description

- | | |
|--|--|
| <ul style="list-style-type: none">• 2.3-inch TFT (51.30x46.30mm)• 320x240 Pixels• 8/16-Bit MCU Interface• Wide Temperature Range• 6:00 Viewing Angle | <ul style="list-style-type: none">• TN, Transmissive• No Touch Panel• 320 NITS• TFT IC: ILI9342C• RoHS Compliant |
|--|--|

Revision History

Date	Rev. No	Page	Summary
10/09/2022	1.0	All	First issue

Description

This is a color active matrix TFT (Thin Film Transistor) LCD (Liquid Crystal Display) that uses amorphous silicon TFT as a switching device. This model is composed of a transmissive type TFT-LCD Panel, driver circuit, and backlight unit. The resolution of the 2.3" TFT-LCD contains 320x240 pixels and can display up to 262K colors.

Features

Input Voltage: 3.3V

TFT Interface: 8/16-Bit MCU

General Information Items	Specification	Unit	Note
	Main Panel		
TFT Display Area (AA)	46.75(H) x 35.06(V) (2.3 inch)	mm	--
Driver Element	TFT active matrix	--	--
Display Colors	262K	colors	--
Number of Pixels	320(RGB)x240	dots	--
TFT Pixel Arrangement	RGB vertical stripe	--	--
Viewing Angle	6:00	o'clock	--
TFT Controller IC	ILI9342C	--	--
Display Mode	Transmissive/Normally White	--	--
Operating Temperature	-20 to +70	°C	--
Storage Temperature	-30 to +80	°C	--

Mechanical Information

Item		Min.	Typ.	Max.	Unit	Note
Module Size	Horizontal (H)	--	51.30	--	mm	--
	Vertical (V)	--	46.30	--	mm	--
	Depth (D)	--	2.31	--	mm	--
Weight		--	8.5	--	g	Approximate

1. Outline Dimensions

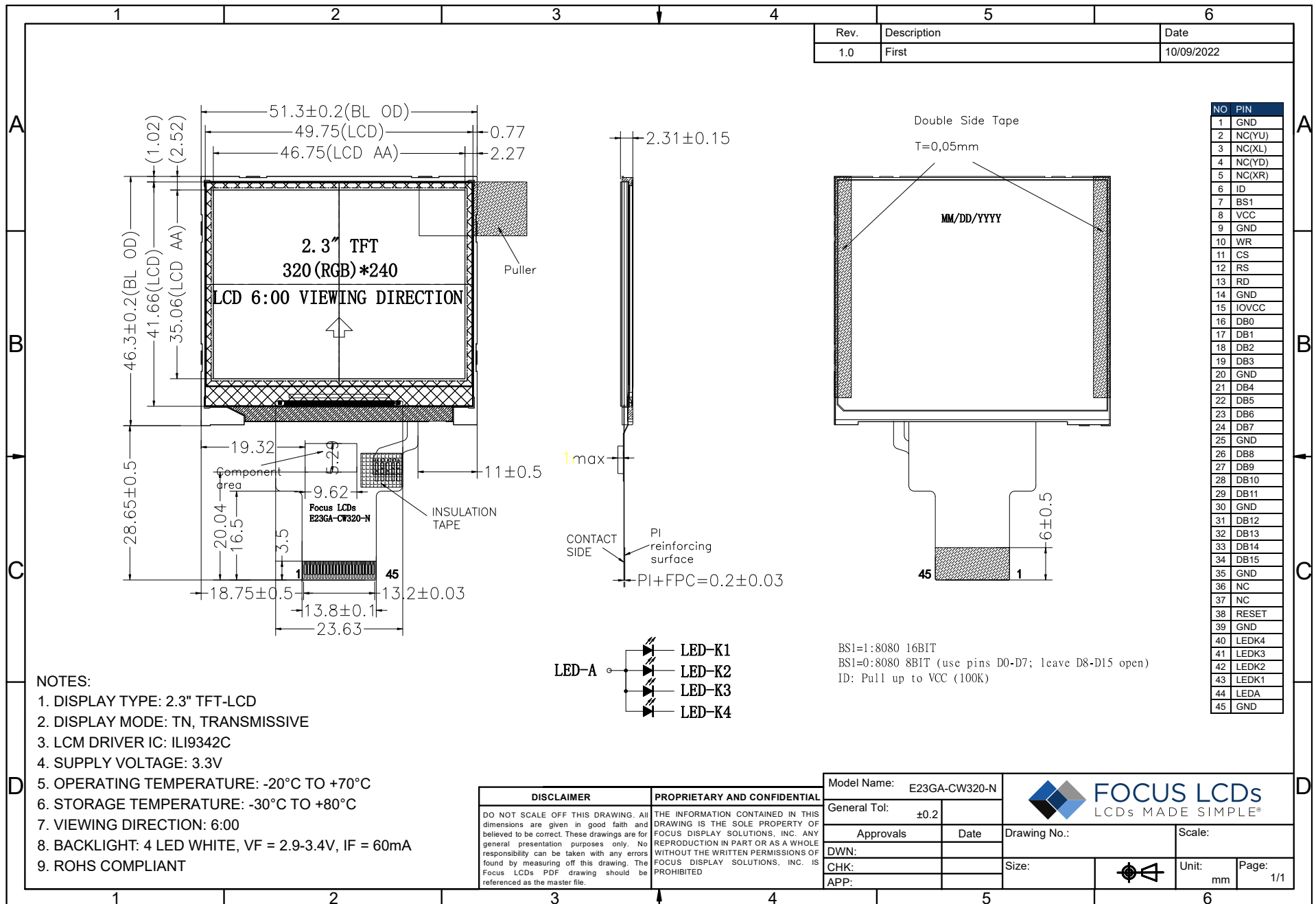

2. Block Diagram

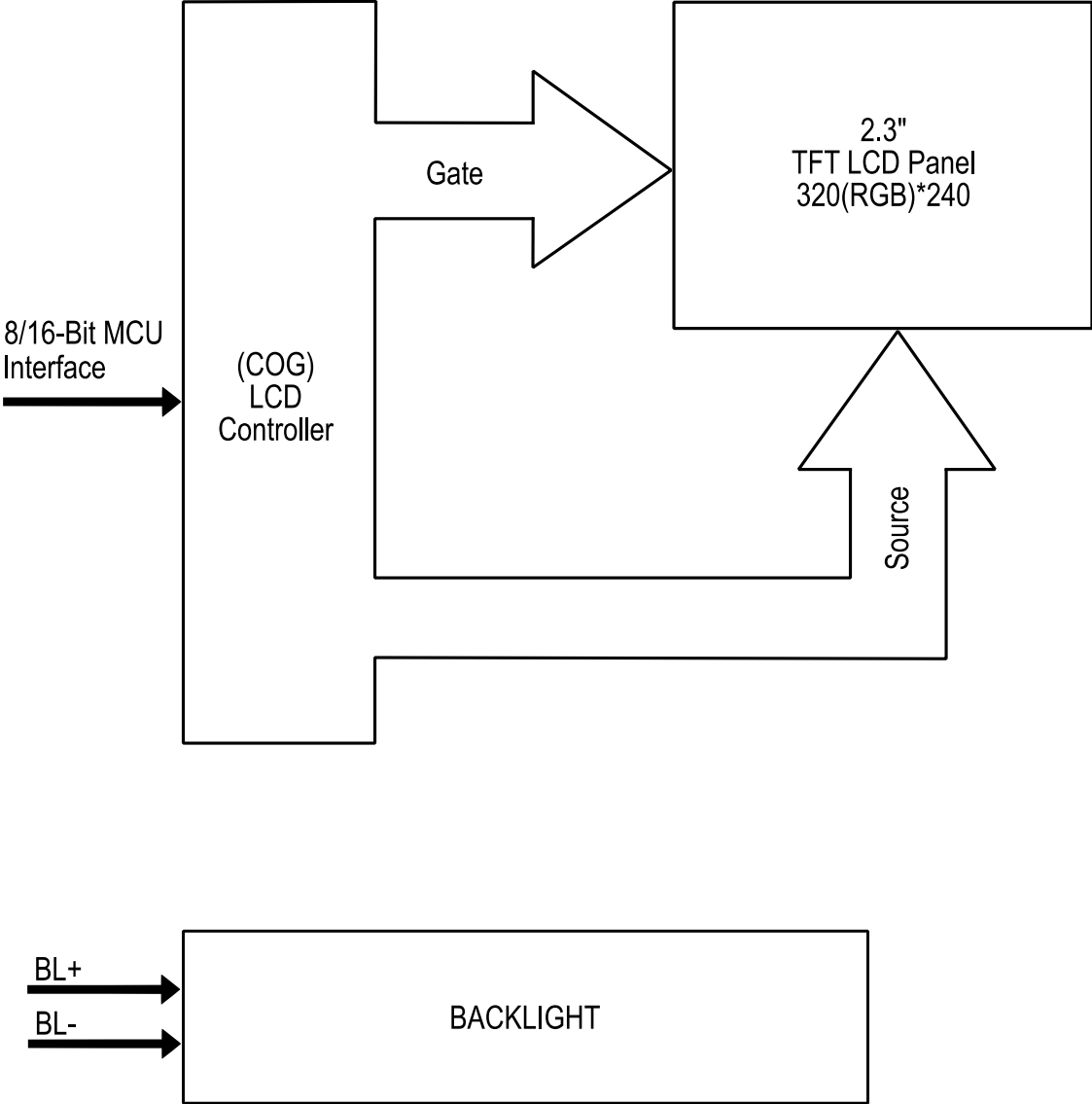

3. Input Terminal Pin Assignment

3.1 TFT Pin Assignment

NO.	Symbol	Description	I/O
1	GND	Ground.	P
2	NC(YU)	No connection.	--
3	NC(XL)	No connection.	--
4	NC(YD)	No connection.	--
5	NC(XR)	No connection.	--
6	ID	Identify pin (connect high ID=1).	I
7	BS1	8080 16-bit or 8-bit control pin (high = 16-bit, low = 8-bit).	I
8	VCC	Power supply for LCD.	P
9	GND	Ground.	P
10	WR	Write strobe signal.	I
11	CS	Chip selection signal pin.	I
12	RS	Data / command selection pin.	I
13	RD	Read strobe signal.	I
14	GND	Ground.	P
15	IOVCC	Power supply for I/O.	P
16	DB0	16-bit parallel bi-directional data bus.	I/O
17	DB1		
18	DB2		
19	DB3		
20	GND	Ground.	P
21	DB4	16-bit parallel bi-directional data bus.	I/O
22	DB5		
23	DB6		
24	DB7		
25	GND	Ground.	P
26	DB8	16-bit parallel bi-directional data bus.	I/O
27	DB9		
28	DB10		
29	DB11		
30	GND	Ground.	P

E23GA-CW320-N

NO.	Symbol	Description	I/O
31	DB12	16-bit parallel bi-directional data bus.	I/O
32	DB13		
33	DB14		
34	DB15		
35	GND	Ground.	P
36	NC	No connection.	--
37	NC	No connection.	--
38	RESET	Reset signal input pin.	I
39	GND	Ground.	P
40	LEDK4	Cathode for LED4 backlighting.	P
41	LEDK3	Cathode for LED3 backlighting.	P
42	LEDK2	Cathode for LED2 backlighting.	P
43	LEDK1	Cathode for LED1 backlighting.	P
44	LEDA	Anode for LED backlighting.	P
45	GND	Ground.	P

4. LCD Optical Characteristics

4.1 Optical Specifications

Item	Symbol	Condition	Min	Typ.	Max	Unit	Note	
Color Gamut	S(%)		--	50	--	%	(5)	
Contrast Ratio	CR	θ=0 Normal viewing angle	400	500	--	%	(2)	
Response Time	Rising		T _R	--	28	30	ms	(4)
	Falling		T _F					
Color Filter Chromaticity	White		W _X	0.2470	0.2870	0.3270		(5)(6)
		W _Y	0.2643	0.3043	0.3443			
Viewing Angle	Hor.	Θ _L	60	70	--	degree	(1)(6)	
		Θ _R	60	70	--			
	Ver.	Θ _T	60	70	--			
		Θ _B	60	70	--			
Option View Direction			6:00				(1)	

Measuring Conditions:

1. VDD=3.3V
2. Ambient temperature of 25°C
3. IL=40mA (backlight current)

Optical Specification Reference Notes:

(1) Definition of Viewing Angle:

The viewing angle is the angle at which the contrast ratio is greater than 10. The viewing angles are determined for the horizontal or 3,9 o'clock direction and the vertical or 6,12 o'clock direction with respect to the optical axis which is normal to the LCD surface.

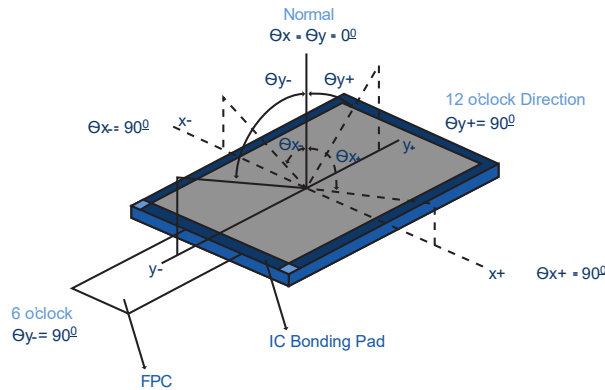

(2) Definition of Contrast Ratio:

Measured at the center point of panel. The contrast ratio (Cr) measured on a module, is the ratio between the luminance (Lw) in a full white area (R=G=B=1) and the luminance (Ld) in a dark area (R=G=B=0).

$$Cr = \frac{L_w}{L_d}$$

(3) Definition of Transmittance (T%):

The transmittance of the panel including the polarizers is measured with electrical driving. The equation for transmittance Tr is:

$$Tr = \frac{I_t}{I_o} \times 100\%$$

I_o = the brightness of the light source.

I_t = the brightness after panel transmission

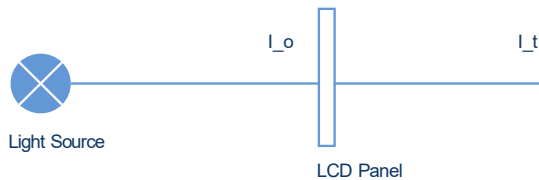

(4) Definition of Response Time (TR, TF):

The rise time 'Tr' is defined as the time for luminance to change from 90% to 10% as a result of a change of the electrical condition. The fall time 'Tf' is defined as the time for luminance to change from 10% to 90% as a result of a change of the electrical condition.

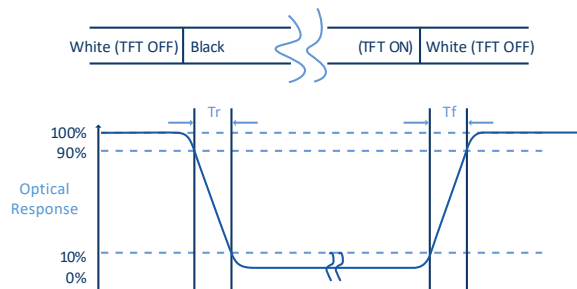

(5) Definition of Color Gamut:

Measuring machine CFT-01. NTSC's Primaries: $R(x,y,Y)$, $G(x,y,Y)$, $B(x,y,Y)$. FPM520 of Westar Display Technologies, INC., which utilized SR-3 for Chromaticity and BM-5A for other optical characteristics. The color chromaticity shall be calculated from the spectral data measured with all pixels first in red, green, blue and white. Measurements shall be made at the center of the panel.

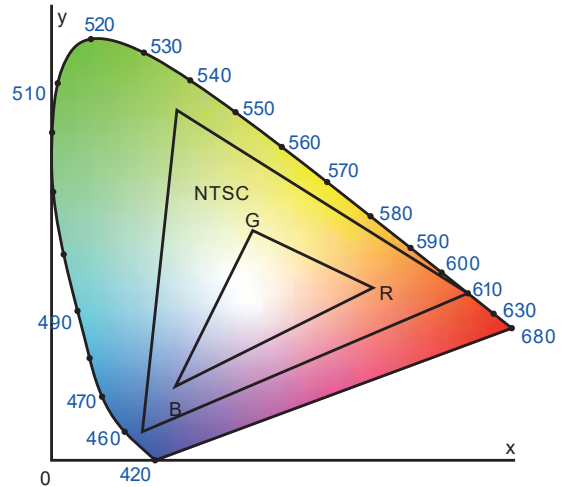
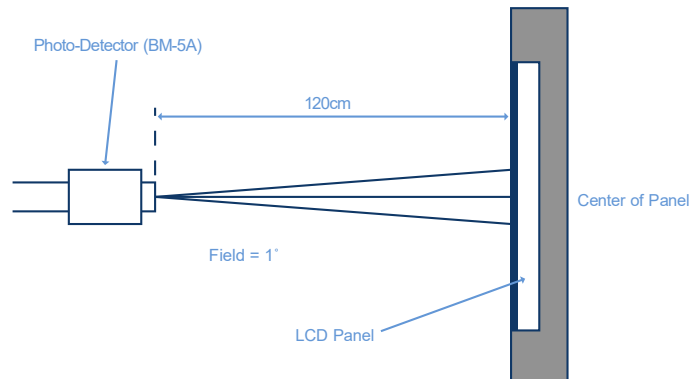
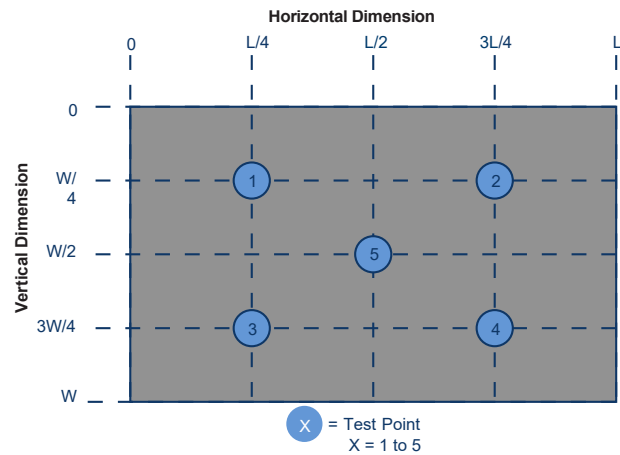
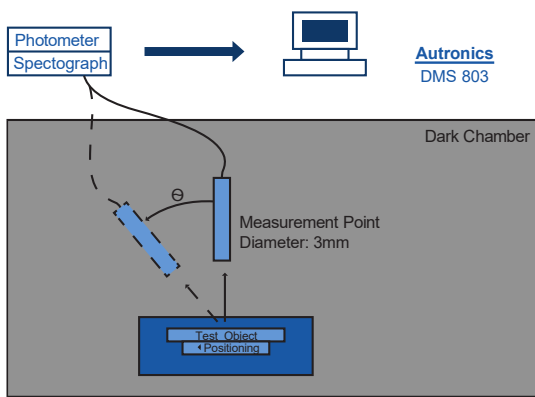

Fig. 1931 CIE Chromaticity Diagram

$$\text{Color Gamut: } S = \frac{\text{Area of RGB Triangle}}{\text{Area of NTSC Triangle}} \times 100\%$$

(6) Definition of Optical Measurement Setup:

The LCD module should be stabilized at a given temperature for 20 minutes to avoid abrupt temperature change during measuring. In order to stabilize the luminance, the measurement should be executed after lighting backlight for 20 minutes.



5. TFT Electrical Characteristics

5.1 Absolute Maximum Rating (Ta=25°C, VSS=0V)

Characteristics	Symbol	Min	Max	Unit
Digital Supply Voltage	VDD	-0.3	4.2	V
Supply Voltage (Logic)	IOVCC	-0.3	4.2	V
Operating Temperature	T _{OP}	-20	+70	°C
Storage Temperature	T _{ST}	-30	+80	°C

NOTE: If the absolute maximum rating of the above parameters is exceeded, even momentarily, the quality of the product may be degraded. Absolute maximum ratings specify the values which the product may be physically damaged if exceeded. Be sure to use the product within the range of the absolute maximum ratings.

5.2 DC Electrical Characteristics

Characteristics	Symbol	Min	Typ.	Max	Unit	Note
Digital Supply Voltage	VDD	2.6	3.3	3.3	V	--
Supply Voltage (Logic)	VDDI	1.65	1.8	2.8	V	--
Positive High-Voltage Power	VGH	--	15	--	V	--
Negative High-Voltage Power	VGL	--	-7.5	--	V	--
TFT Common Voltage	VCOM	-1.5	--	3.5	V	--
Data (RGB Signal) Voltage	VSIG	0.2	--	5.2	V	--

5.3 LED Backlight Characteristics

The backlight system is edge lighting type with 4 LED Chips

Item	Symbol	Min	Typ.	Max	Unit	Note
Forward Current	I_F	--	60	--	mA	--
Forward Voltage	V_F	2.9	3.0	3.4	V	--
LCM Luminance	L_V	--	320	--	cd/m ²	(3)
LED Lifetime	Hr	50000	--	--	hour	(1)(2)
Uniformity	Avg	70	80	--	%	(3)

Note 1: LED lifetime (Hr) can be defined as the time in which it continues to operate under the condition: $T_a=25 \pm 3^\circ\text{C}$, typical IL value indicated in the above table until the brightness becomes less than 50%.

Note 2: The "LED lifetime" is defined as the module brightness decrease to 50% original brightness at $T_a=25^\circ\text{C}$ and $I_F = 60\text{mA}$. The LED lifetime could be decreased if operating I_F is larger than 60mA. The constant current driving method is suggested.

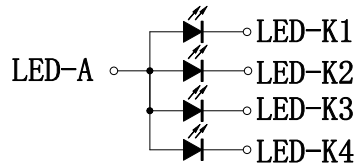

BL CIRCUIT DIAGRAM

Note 3: Luminance Uniformity of these 9 points is defined as below:

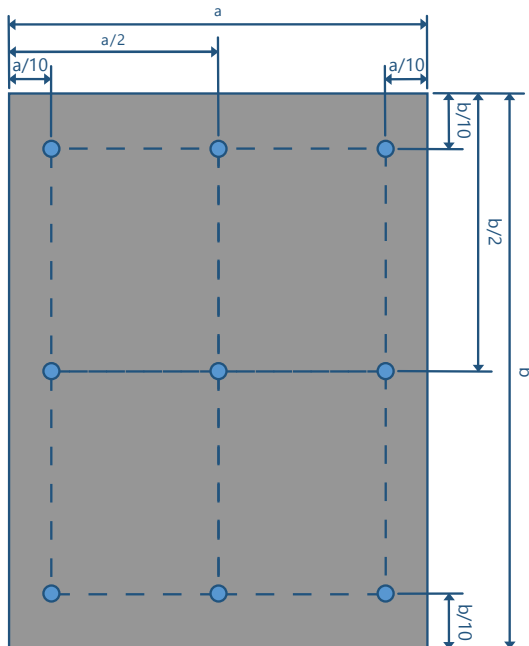

$$\text{Luminance} = \frac{\text{(Total Luminance of 9 Points)}}{9}$$

$$\text{Uniformity} = \frac{\text{Minimum Luminance in 9 Points (1-9)}}{\text{Maximum Luminance in 9 Points (1-9)}}$$

6. TFT AC Characteristics

6.1 Display Parallel 8/16-bit Interface Timing Characteristics (8080-I System)

For display parallel 8/16-bit interface timing characteristics (8080-I system) diagrams and table, see page 228 of the data sheet for controller IC ILI9342. The data sheet can be found here:

<https://focuslcds.com/wp-content/uploads/Drivers/ILI9342C.pdf>

6.2 Power On/Off Sequence

For the recommended power on/off sequence diagrams and tables, see pages 208–209 of the controller IC ILI9342C data sheet. The data sheet can be found here:

<https://focuslcds.com/wp-content/uploads/Drivers/ILI9342C.pdf>

6.3 Reset Timing Characteristics

For reset timing characteristics charts and tables, see page 222 of the data sheet for controller IC ILI9342C. The data sheet can be found here:

<https://focuslcds.com/wp-content/uploads/Drivers/ILI9342C.pdf>

7. Quality Inspection Standards

For TFT quality inspection standards, please see the following link:

<https://focuslcds.com/lcd-resources/tft-quality-inspection-standards/>

8. Cautions and Handling Precautions

8.1 Handling and Operating the Module

1. When the module is assembled, it should be attached to the system firmly. Do not warp or twist the module during assembly work.
2. Protect the module from physical shock or any force. In addition to damage, this may cause improper operation or damage to the module and back-light unit.
3. Note that polarizer is very fragile and could be easily damaged. Do not press or scratch the surface.
4. Do not allow drops of water or chemicals to remain on the display surface. If you have the droplets for a long time, staining and discoloration may occur.
5. If the surface of the polarizer is dirty, clean it using some absorbent cotton or soft cloth.
6. The desirable cleaners are water, IPA (Isopropyl Alcohol) or Hexane. Do not use ketene type materials (ex. Acetone), Ethyl alcohol, Toluene, Ethyl acid or Methyl chloride. It might permanent damage to the polarizer due to chemical reaction.
7. If the liquid crystal material leaks from the panel, it should be kept away from the eyes or mouth. In case of contact with hands, legs, or clothes, it must be washed away thoroughly with soap.
8. Protect the module from static; it may cause damage to the CMOS ICs.
9. Use fingerstalls with soft gloves in order to keep display clean during the incoming inspection and assembly process.
10. Do not disassemble the module.
11. Protection film for polarizer on the module shall be slowly peeled off just before use so that the electrostatic charge can be minimized.
12. Pins of I/F connector shall not be touched directly with bare hands.
13. Do not connect, disconnect the module in the "Power ON" condition.
14. Power supply should always be turned on/off by the item Power On Sequence & Power Off Sequence.

8.2 Storage and Transportation

1. Do not leave the panel in high temperature, and high humidity for a long time. It is highly recommended to store the module with temperature from 0 to 35°C and relative humidity of less than 70%.
2. Do not store the TFT-LCD module in direct sunlight.
3. The module shall be stored in a dark place. When storing the modules for a long time, be sure to adopt effective measures for protecting the modules from strong ultraviolet radiation, sunlight, or fluorescent light.
4. It is recommended that the modules should be stored under a condition where no condensation is allowed. Formation of dewdrops may cause an abnormal operation or a failure of the module. In particular, the greatest possible care should be taken to prevent any module from being operated where condensation has occurred inside.
5. This panel has its circuitry FPC on the bottom side and should be handled carefully in order not to be stressed.