



FOCUS LCDs

LCDs MADE SIMPLE®



ISO 9001

QUALITY
MANAGEMENT

MEDICAL | INDUSTRIAL | DEFENSE | AGRICULTURE | FOOD SERVICE

E24BA-CW1000-N

Product Description

- | | |
|--|---|
| <ul style="list-style-type: none">• 2.4-inch TFT (42.72x60.26mm)• 240x320 Pixels• 8/16-Bit MCU Interface• Wide Temperature Range• 6:00 Viewing Angle | <ul style="list-style-type: none">• TN, Transmissive• No Touch Panel• 1000 NITS• TFT IC: ST7789VI• RoHS Compliant |
|--|---|

Revision History

Date	Rev. No	Page	Summary
08/08/2022	1.0	All	First issue

Description

This is a color active matrix TFT (Thin Film Transistor) LCD (Liquid Crystal Display) that uses amorphous silicon TFT as a switching device. This model is composed of a transmissive type TFT-LCD Panel, driver circuit, and backlight unit. The resolution of the 2.4" TFT-LCD contains 240x320 pixels and can display up to 262K colors.

Features

Input Voltage: 3.3V

TFT Interface: 8/16-Bit MCU

General Information Items	Specification	Unit	Note
	Main Panel		
TFT Display Area (AA)	36.72(H) x 48.96(V) (2.4 inch)	mm	--
Driver Element	TFT active matrix	--	--
Display Colors	262K	colors	--
Number of Pixels	240(RGB)x320	dots	--
TFT Pixel Arrangement	RGB vertical stripe	--	--
Pixel Pitch	0.153 (H) x 0.153 (V)	mm	--
Viewing Angle	6:00	o'clock	--
Gray Scale Inversion Direction	12:00	o'clock	
TFT Controller IC	ST7789VI	--	--
Display Mode	Transmissive/Normally White	--	--
Operating Temperature	-20 to +70	°C	--
Storage Temperature	-30 to +80	°C	--

Note 1: Color tune is slightly changed by temperature and driving voltage.

Note 2: Without FPC and solder.

Mechanical Information

Item		Min.	Typ.	Max.	Unit	Note
Module Size	Horizontal (H)	--	42.72	--	mm	--
	Vertical (V)	--	60.26	--	mm	--
	Depth (D)	--	2.40	--	mm	--
Weight		--	13	--	g	Approximate

1. Outline Dimensions

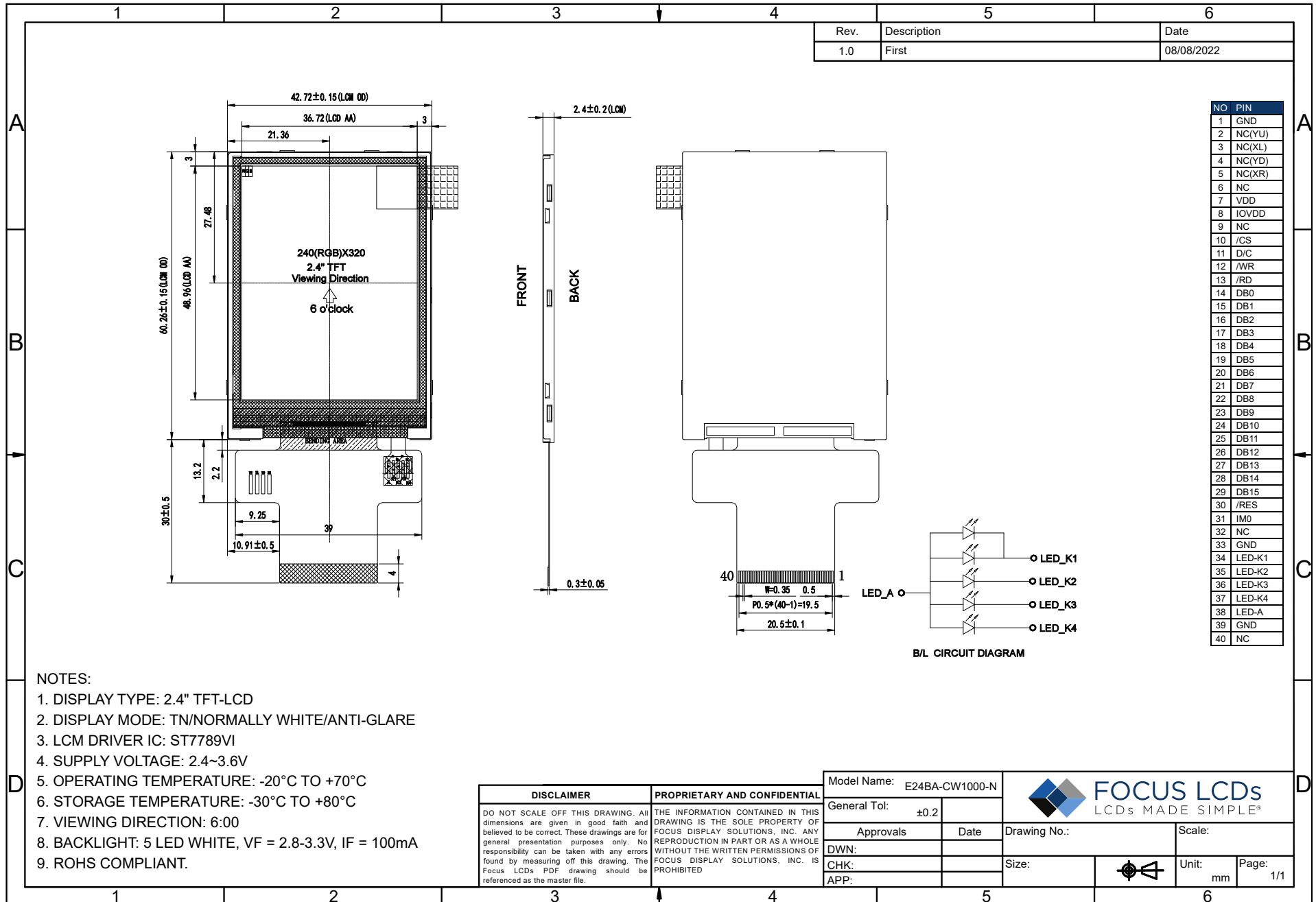

2. Block Diagram

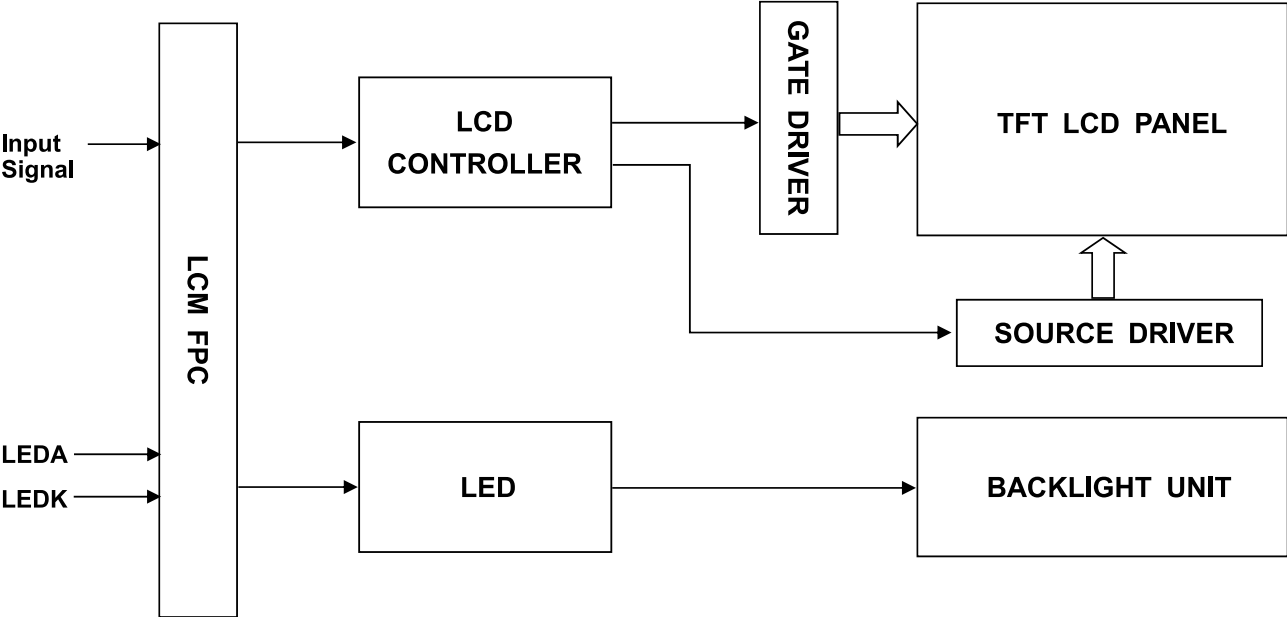

3. Input Terminal Pin Assignment

3.1 TFT Pin Assignment

NO.	Symbol	Description	I/O
1	GND	Ground.	P
2	NC(YU)	Not connected (RTP pin).	--/I
3	NC(XL)	Not connected (RTP pin).	--/I
4	NC(YD)	Not connected (RTP pin).	--/I
5	NC(XR)	Not connected (RTP pin).	--/I
6	NC	Not connected.	--
7	VDD	Power supply for LCD (3.3V).	P
8	IOVDD	Power supply for logic (1.8V).	P
9	NC	Not connected.	--
10	/CS	Chip select signal.	I
11	D/C	Data/Command selection: 1=data; 0=command.	I
12	/WR	Active low write signal.	I
13	/RD	Active low read signal.	I
14-29	DB0~DB15	Data bus: 8 bit use DB8~DB15; 16 bit use DB0~DB15.	I
30	/RES	Active low reset signal.	I
31	IM0	IM0=0: 16bit i80; IM0=1: 8 bit i80.	I
32	NC	Not connected.	--
33	GND	Ground.	P
34	LED-K1	Backlight cathode (ground).	P
35	LED-K2	Backlight cathode (ground).	P
36	LED-K3	Backlight cathode (ground).	P
37	LED-K4	Backlight cathode (ground).	P
38	LED-A	Power supply for LED backlight(+).	P
39	GND	Ground.	P
40	NC	Not connected.	--

4. LCD Optical Characteristics

4.1 Optical Specifications

Item	Symbol	Condition	Min	Typ.	Max	Unit	Note	
Contrast Ratio	CR	$\theta=0$ Normal viewing angle	--	250	--	%	(2)	
Response Time	Rising		T_R	--	16	32	ms	(4)
	Falling		T_F					
Color Filter Chromaticity	White		W_X	0.2510	0.2810	0.3110		(5)(6)
			W_Y	0.2520	0.2820	0.3120		
	Red		R_X	0.5470	0.5770	0.6070		
			R_Y	0.3080	0.3380	0.3680		
	Green		G_X	0.3040	0.3340	0.3640		
			G_Y	0.5630	0.5930	0.6230		
	Blue		B_X	0.1240	0.1540	0.1840		
		B_Y	0.0250	0.0550	0.0850			
Viewing Angle	Hor.	Θ_L	--	60	--	degree	(1)(6)	
		Θ_R	--	60	--			
	Ver.	Θ_T	--	50	--			
		Θ_B	--	60	--			
Option View Direction			6:00				(1)	

Measuring Conditions:

1. Dark Room
2. Ambient Temperature of $25\pm 2^\circ\text{C}$
3. 5 Minute Warm up

Optical Specification Reference Notes:

(1) Definition of Viewing Angle:

The viewing angle is the angle at which the contrast ratio is greater than 10. The viewing angles are determined for the horizontal or 3,9 o'clock direction and the vertical or 6,12 o'clock direction with respect to the optical axis which is normal to the LCD surface.

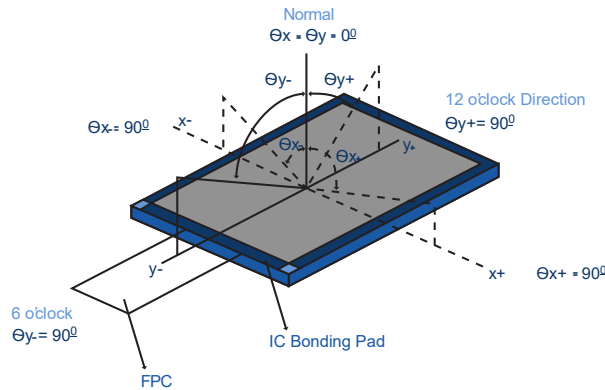

(2) Definition of Contrast Ratio:

Measured at the center point of panel. The contrast ratio (Cr) measured on a module, is the ratio between the luminance (Lw) in a full white area (R=G=B=1) and the luminance (Ld) in a dark area (R=G=B=0).

$$Cr = \frac{L_w}{L_d}$$

(3) Definition of Transmittance (T%):

The transmittance of the panel including the polarizers is measured with electrical driving. The equation for transmittance Tr is:

$$Tr = \frac{I_t}{I_o} \times 100\%$$

I_o = the brightness of the light source.

I_t = the brightness after panel transmission

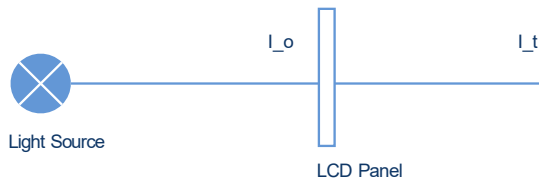

(4) Definition of Response Time (TR, TF):

The rise time 'Tr' is defined as the time for luminance to change from 90% to 10% as a result of a change of the electrical condition. The fall time 'Tf' is defined as the time for luminance to change from 10% to 90% as a result of a change of the electrical condition.

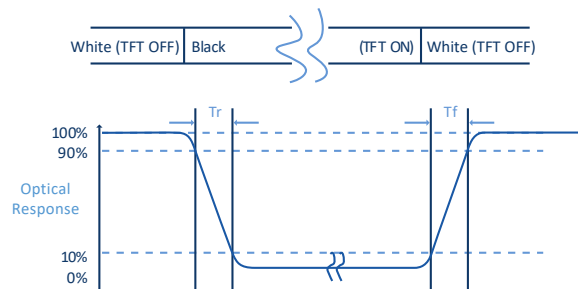

(5) Definition of Color Gamut:

Measuring machine CFT-01. NTSC's Primaries: $R(x,y,Y)$, $G(x,y,Y)$, $B(x,y,Y)$. FPM520 of Westar Display Technologies, INC., which utilized SR-3 for Chromaticity and BM-5A for other optical characteristics. The color chromaticity shall be calculated from the spectral data measured with all pixels first in red, green, blue and white. Measurements shall be made at the center of the panel.

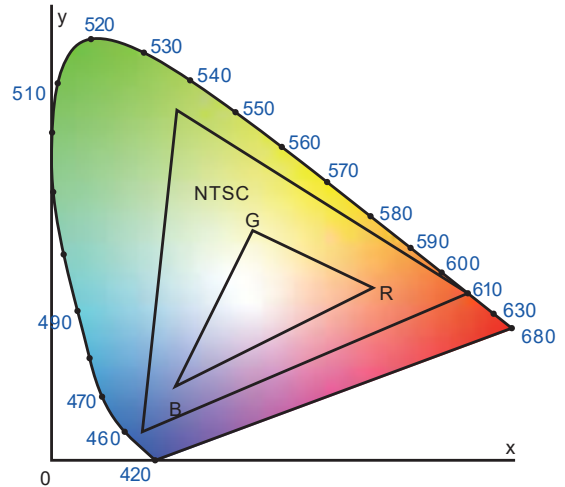
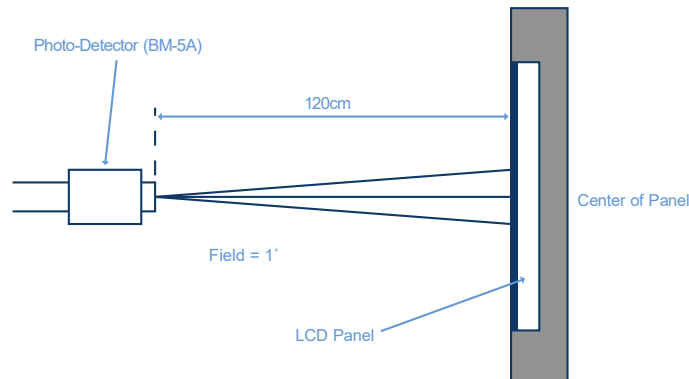
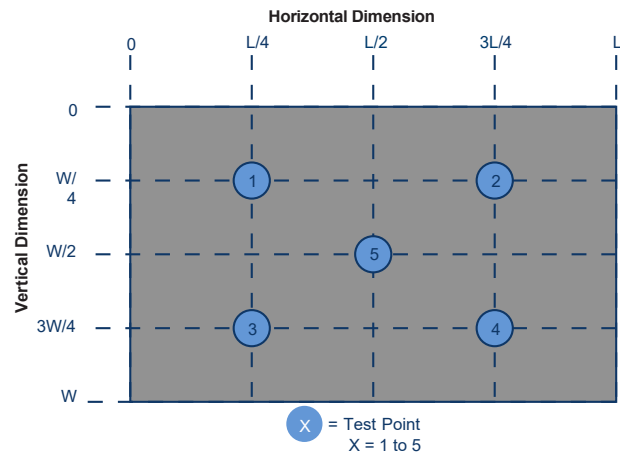
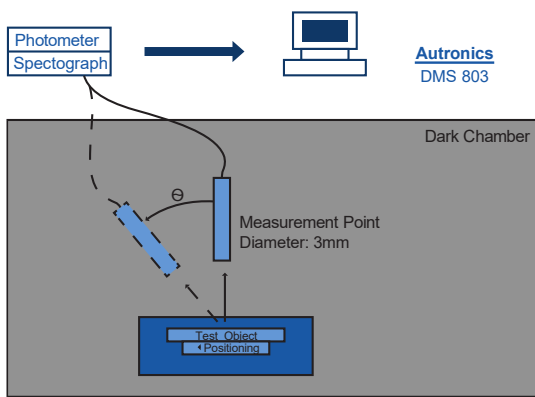

Fig. 1931 CIE Chromaticity Diagram

$$\text{Color Gamut: } S = \frac{\text{Area of RGB Triangle}}{\text{Area of NTSC Triangle}} \times 100\%$$

(6) Definition of Optical Measurement Setup:

The LCD module should be stabilized at a given temperature for 20 minutes to avoid abrupt temperature change during measuring. In order to stabilize the luminance, the measurement should be executed after lighting backlight for 20 minutes.



5. TFT Electrical Characteristics

5.1 Absolute Maximum Rating (Ta=25°C, VSS=0V)

Characteristics	Symbol	Min	Max	Unit
Digital Supply Voltage	VDD	-0.3	4.6	V
Operating Temperature	T _{OP}	-20	+70	°C
Storage Temperature	T _{ST}	-30	+80	°C

NOTE: If the absolute maximum rating of the above parameters is exceeded, even momentarily, the quality of the product may be degraded. Absolute maximum ratings specify the values which the product may be physically damaged if exceeded. Be sure to use the product within the range of the absolute maximum ratings.

5.2 DC Electrical Characteristics

Characteristics	Symbol	Min	Typ.	Max	Unit	Note
Digital Supply Voltage	VDD	2.4	3.3	3.6	V	--
Level Input Voltage	V _{IH}	0.7*VDD	--	VDD	V	--
	V _{IL}	VSS	--	0.3*VDD	V	--

5.3 LED Backlight Characteristics

The backlight system is edge lighting type with 5 LED Chips

Item	Symbol	Min	Typ.	Max	Unit	Note
Forward Current	I_F	--	100	--	mA	--
Forward Voltage	V_F	2.8	3.1	3.3	V	--
LCM Luminance	L_V	850	1000	--	cd/m ²	(3)
LED Lifetime	Hr	--	50000	--	hour	(1)(2)
Uniformity	Avg	75	80	--	%	(3)

Note 1: LED lifetime (Hr) can be defined as the time in which it continues to operate under the condition: $T_a=25 \pm 3^\circ\text{C}$, typical IL value indicated in the above table until the brightness becomes less than 50%.

Note 2: The "LED lifetime" is defined as the module brightness decrease to 50% original brightness at $T_a=25^\circ\text{C}$ and $I_F = 100\text{mA}$. The LED lifetime could be decreased if operating I_F is larger than 100mA. The constant current driving method is suggested.

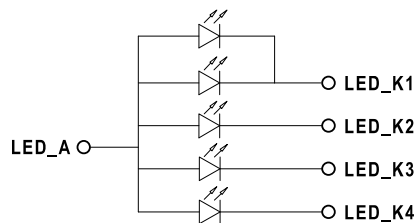

BL CIRCUIT DIAGRAM

Note 3: Luminance Uniformity of these 9 points is defined as below:

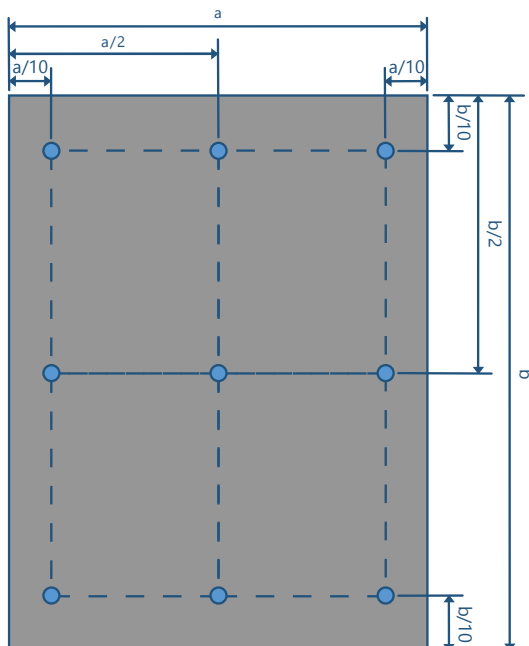

$$\text{Luminance} = \frac{(\text{Total Luminance of 9 Points})}{9}$$

$$\text{Uniformity} = \frac{\text{Minimum Luminance in 9 Points (1-9)}}{\text{Maximum Luminance in 9 Points (1-9)}}$$

6. TFT AC Characteristics

6.1 8080 Series MCU Parallel Interface Timing Characteristics: 18/16/9/8-bit Bus

For 8080 Series MCU parallel interface timing characteristics, diagrams and tables, see table and diagrams on pages 41-42 of the data sheet for controller ST7789V. The data sheet can be found here: <https://focuslcds.com/wp-content/uploads/Drivers/ST7789VI.pdf>

6.2 Display Serial Interface Timing Characteristics (3-line serial):

For serial interface timing characteristics (3-line serial), diagram and table, see the table and diagram on page 43 of the data sheet for controller ST7789V. The data sheet can be found here: <https://focuslcds.com/wp-content/uploads/Drivers/ST7789VI.pdf>

6.3 Display Serial Interface Timing Characteristics (4-line serial):

For serial interface timing characteristics (4-line serial), diagram and table, see the table and diagram on page 44 of the data sheet for controller ST7789V. The data sheet can be found here: <https://focuslcds.com/wp-content/uploads/Drivers/ST7789VI.pdf>

6.4 Parallel RGB Interface Timing Characteristics

For parallel RGB interface timing characteristics tables and diagram, see pages 46-47 of the data sheet for controller ST7789V. The data sheet can be found here: <https://focuslcds.com/wp-content/uploads/Drivers/ST7789VI.pdf>

6.5 Reset Timing Characteristics

For the reset timing characteristics tables and diagrams, see pages 48-49 of the data sheet for controller ST7789V. The data sheet can be found here: <https://focuslcds.com/wp-content/uploads/Drivers/ST7789VI.pdf>

7. Quality Inspection Standards

For TFT quality inspection standards, please see the following link: <https://focuslcds.com/lcd-resources/tft-quality-inspection-standards/>

8. Cautions and Handling Precautions

8.1 Handling and Operating the Module

1. When the module is assembled, it should be attached to the system firmly. Do not warp or twist the module during assembly work.
2. Protect the module from physical shock or any force. In addition to damage, this may cause improper operation or damage to the module and back-light unit.
3. Note that polarizer is very fragile and could be easily damaged. Do not press or scratch the surface.
4. Do not allow drops of water or chemicals to remain on the display surface. If you have the droplets for a long time, staining and discoloration may occur.
5. If the surface of the polarizer is dirty, clean it using some absorbent cotton or soft cloth.
6. The desirable cleaners are water, IPA (Isopropyl Alcohol) or Hexane. Do not use ketene type materials (ex. Acetone), Ethyl alcohol, Toluene, Ethyl acid or Methyl chloride. It might permanent damage to the polarizer due to chemical reaction.
7. If the liquid crystal material leaks from the panel, it should be kept away from the eyes or mouth. In case of contact with hands, legs, or clothes, it must be washed away thoroughly with soap.
8. Protect the module from static; it may cause damage to the CMOS ICs.
9. Use fingerstalls with soft gloves in order to keep display clean during the incoming inspection and assembly process.
10. Do not disassemble the module.
11. Protection film for polarizer on the module shall be slowly peeled off just before use so that the electrostatic charge can be minimized.
12. Pins of I/F connector shall not be touched directly with bare hands.
13. Do not connect, disconnect the module in the "Power ON" condition.
14. Power supply should always be turned on/off by the item Power On Sequence & Power Off Sequence.

8.2 Storage and Transportation

1. Do not leave the panel in high temperature, and high humidity for a long time. It is highly recommended to store the module with temperature from 0 to 35°C and relative humidity of less than 70%.
2. Do not store the TFT-LCD module in direct sunlight.
3. The module shall be stored in a dark place. When storing the modules for a long time, be sure to adopt effective measures for protecting the modules from strong ultraviolet radiation, sunlight, or fluorescent light.
4. It is recommended that the modules should be stored under a condition where no condensation is allowed. Formation of dewdrops may cause an abnormal operation or a failure of the module. In particular, the greatest possible care should be taken to prevent any module from being operated where condensation has occurred inside.
5. This panel has its circuitry FPC on the bottom side and should be handled carefully in order not to be stressed.