



FOCUS LCDs

LCDs MADE SIMPLE[®]



ISO 9001

QUALITY
MANAGEMENT

MEDICAL | INDUSTRIAL | DEFENSE | AGRICULTURE | FOOD SERVICE

E28RA-T-XS150-CB

Product Description

- | | |
|---|---|
| <ul style="list-style-type: none">• 2.8-inch TFT (52.90x79.30mm)• 240x320 Pixels• 8/9/16/18-Bit MCU, 3/4-SPI+16/18-Bit RGB, 3/4-line Serial Interfaces• Special Temperature Range• All Viewing Angles | <ul style="list-style-type: none">• TN, Transflective• Capacitive Touch Panel• 150 NITS• TFT IC: ST7789V2, CTP IC: FT5446• RoHS Compliant |
|---|---|

Revision History

Date	Rev. No	Page	Summary
07/03/2024	1.0	All	First issue

Description

This is a color active matrix TFT (Thin Film Transistor) LCD (Liquid Crystal Display) that uses amorphous silicon TFT as a switching device. This model is composed of a transfective type TFT-LCD Panel, driver circuit, capacitive touch panel, and backlight unit. The resolution of the 2.8" TFT-LCD contains 240x320 pixels and can display up to 65K/262K colors.

Features

Input Voltage: 3.3V

TFT Interface: 8/9/16/18-Bit MCU, 3/4-SPI+16/18-Bit RGB, 3/4-line Serial

CTP Interface: I2C

General Information Items	Specification	Unit	Note
	Main Panel		
TFT Display Area (AA)	43.20(H) x 57.60(V) (2.8 inch)	mm	--
Driver Element	TFT active matrix	--	--
Display Colors	65K/262K	colors	--
Number of Pixels	240(RGB)x320	dots	--
TFT Pixel Arrangement	RGB vertical stripe	--	--
Pixel Pitch	0.18 (H) x 0.18 (V)	mm	--
Viewing Angle	ALL	o'clock	--
TFT Controller IC	ST7789V2	--	--
CTP Driver IC	FT5446	--	--
Display Mode	Transflective/Normally Black	--	--
Touch Points	Two points	--	--
Operating Temperature	-30 to +80	°C	--
Storage Temperature	-30 to +85	°C	--

Mechanical Information

Item		Min.	Typ.	Max.	Unit	Note
Module Size	Horizontal (H)	--	52.90	--	mm	--
	Vertical (V)	--	79.30	--	mm	--
	Depth (D)	--	3.95	--	mm	--
Weight		--	31	--	g	Approximate

2. Block Diagram

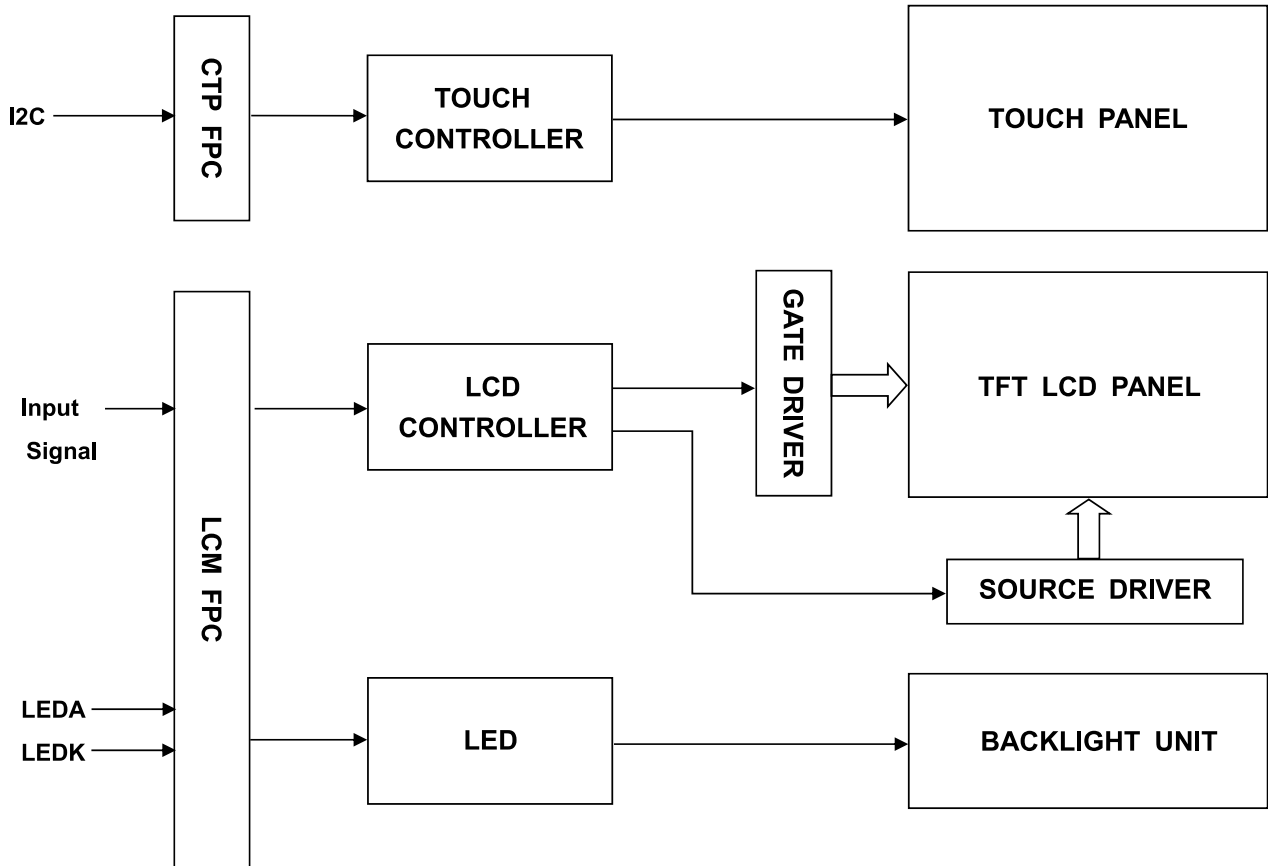

3. Input Terminal Pin Assignment

3.1 TFT Pin Assignment

NO.	Symbol	Description	I/O
1	XR	No connection.	--
2	YD	No connection.	--
3	XL	No connection.	--
4	YU	No connection.	--
5	GND	Ground.	P
6	GND	Ground.	P
7	VCC	Supply voltage (3.3V).	I
8	VCC	Supply voltage (3.3V).	I
9	IOVCC	Power supply for I/O System.	I
10	SDO	SPI interface output pin. The data is output on the falling edge of the SCL signal. If not used, let this pin open.	O
11-28	DB17-DB0	18-bit parallel bi-directional data bus for MCU system and RGB interface mode. Fix this pin to GND if not used.	I/O
29	DIN(SDA)	Serial input signal. The data is latched on the rising edge of the SCL signal. Fix this pin to IOVCC or GND when not in use.	I/O
30	PCLK	Dot clock signal for RGB interface operation. Fix this pin to IOVCC or GND when not in use.	I
31	DE	Data enable signal for RGB interface operation. Fix this pin to IOVCC or GND when not in use.	I
32	HSYNC	Line synchronizing signal for RGB interface operation. Fix this pin to IOVCC or GND when not in use.	I
33	VSYNC	Frame synchronizing signal for RGB interface operation. Fix this pin to IOVCC or GND when not in use.	I
34	RD	Read enable in 8080 MCU parallel interface. Fix this pin to IOVCC or GND when not in use.	I
35	WR(SPI-RS)	Write enable in MCU parallel interface. Display data/command selection pin in 4-line serial interface. Second data lane in 2 data lane serial interface. Fix this pin to IOVCC or GND when not in use.	I
36	RS(SPI-SCL)	Display data/command selection pin in parallel interface. This pin is used to be serial interface clock. RS='1': display data or parameter. RS='0': command data. Fix this pin to IOVCC or GND when not in use.	I
37	CS	Chip select input pin ("Low" enable). Fix this pin to IOVCC or GND when not in use.	I
38	RESET	This signal will reset the device and must be applied to properly initialize the chip.	I

39	IM0	MPU parallel interface bus and serial interface select.					I
		IM2	IM1	IM0	Interface type	DB Pin in use	
40	IM1	0	0	0	DBI Tyb_ 16-bit interface	DB17-DB10, DB8-DB1	
		0	0	1	DBI Tyb_ 8-bit interface	DB17-DB10	
		0	1	0	DBI Tyb_ 18-bit interface	DB17-DB0	
		0	1	1	DBI Tyb_ 9-bit interface	DB17-DB9	
		1	0	1	3-Wire 9 BIT data serial interface	SDA SCL CS	
41	IM2	1	1	0	4-Wire 8 BIT data serial interface	SDA SCL CS RS	
		If using the RGB mode, a serial interface must be selected. Fix pins to IOVCC or GND when not in use.					
42	NC	No connection.					
43	LEDA	Anode pin of backlight.					P
44	NC	No connection.					--
45	LEDK	Cathode pin of backlight.					P

3.2 CTP Pin Assignment

NO.	Symbol	Description	I/O
1	GND	Ground.	P
2	VDDIO	I/O power supply voltage.	P
3	VDD	Supply voltage.	P
4	SCL	I2C clock input.	I
5	SDA	I2C data input and output.	I/O
6	INT	External interrupt to the host.	I
7	RST	External reset, low is active.	I
8	GND	Ground.	P

4. LCD Optical Characteristics

4.1 Optical Specifications (Reflective Mode – BLU OFF)

Item	Symbol	Condition	Min	Typ.	Max	Unit	Note
Reflection Ratio (with polarizer)	R(%)	$\theta=0$ Normal viewing angle	5.6	7.5	--	%	
Contrast Ratio	CR		5	7	--	%	(2)
Viewing Angle	Hor.	Θ_L	50	60	--	degree	(1)(6)
		Θ_R	50	60	--		
	Ver.	Θ_T	50	60	--		
		Θ_B	50	60	--		

4.2 Optical Specifications (Transmissive Mode – BLU ON)

Item	Symbol	Condition	Min	Typ.	Max	Unit	Note
Color Gamut	S(%)		9.0	10.6	--	%	(5)
Transmittance (with polarizer)	T(%)		0.9	1.2	--	%	
Contrast Ratio	CR		100	120	--	%	(2)
Response Time	Rising	T_R	--	--	30	ms	(4)
	Falling	T_F					
Color Filter Chromaticity	White	W_X	0.2580	0.2980	0.3380		(5)(6)
		W_Y	0.2700	0.3100	0.3500		
	Red	R_X	0.3480	0.3880	0.4280		
		R_Y	0.2530	0.2930	0.3330		
	Green	G_X	0.2870	0.3270	0.3670		
		G_Y	0.3950	0.4350	0.4750		
	Blue	B_X	0.1590	0.1990	0.2390		
		B_Y	0.1430	0.1830	0.2230		
Viewing Angle	Hor.	Θ_L	25	35	--	degree	(1)(6)
		Θ_R	25	35	--		
	Ver.	Θ_T	30	40	--		
		Θ_B	25	35	--		
Option View Direction			All				(1)

Measuring Conditions:

1. Dark Room
2. Ambient Temperature of $25\pm 2^\circ\text{C}$
3. 15 Minute Warm up

Optical Specification Reference Notes:

(1) Definition of Viewing Angle:

The viewing angle is the angle at which the contrast ratio is greater than 10. The viewing angles are determined for the horizontal or 3,9 o'clock direction and the vertical or 6,12 o'clock direction with respect to the optical axis which is normal to the LCD surface.

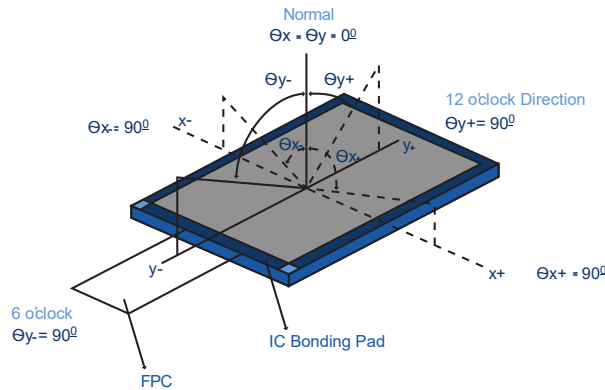

(2) Definition of Contrast Ratio:

Measured at the center point of panel. The contrast ratio (Cr) measured on a module, is the ratio between the luminance (Lw) in a full white area (R=G=B=1) and the luminance (Ld) in a dark area (R=G=B=0).

$$Cr = \frac{L_w}{L_d}$$

(3) Definition of Transmittance (T%):

The transmittance of the panel including the polarizers is measured with electrical driving. The equation for transmittance Tr is:

$$Tr = \frac{I_t}{I_o} \times 100\%$$

I_o = the brightness of the light source.

I_t = the brightness after panel transmission

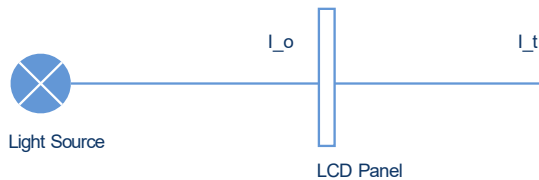

(4) Definition of Response Time (TR, TF):

The rise time 'Tr' is defined as the time for luminance to change from 90% to 10% as a result of a change of the electrical condition. The fall time 'Tf' is defined as the time for luminance to change from 10% to 90% as a result of a change of the electrical condition.

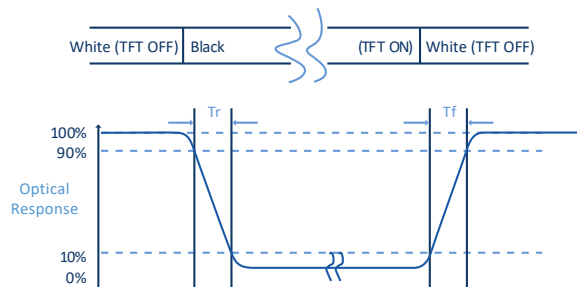

(5) Definition of Color Gamut:

Measuring machine CFT-01. NTSC's Primaries: $R(x,y,Y)$, $G(x,y,Y)$, $B(x,y,Y)$. FPM520 of Westar Display Technologies, INC., which utilized SR-3 for Chromaticity and BM-5A for other optical characteristics. The color chromaticity shall be calculated from the spectral data measured with all pixels first in red, green, blue and white. Measurements shall be made at the center of the panel.

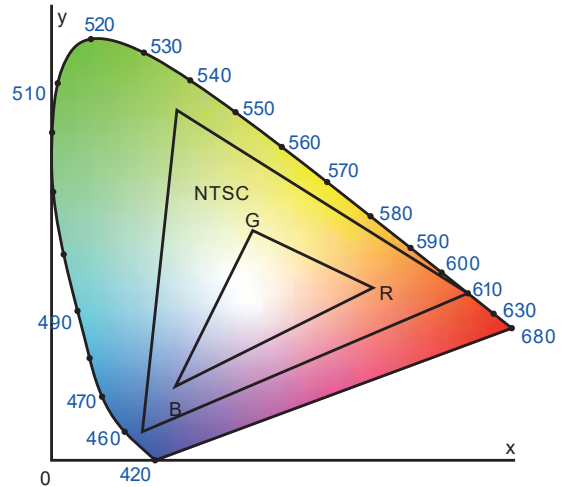
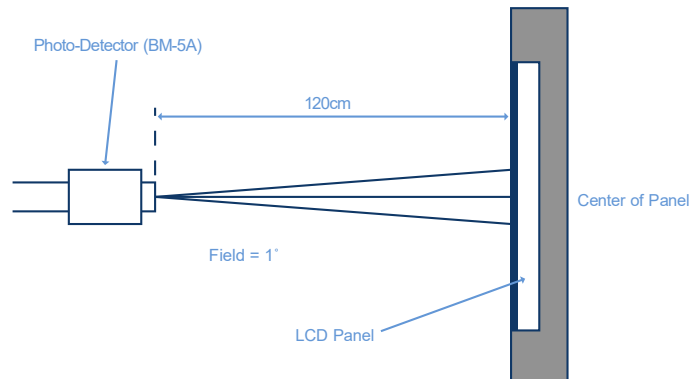
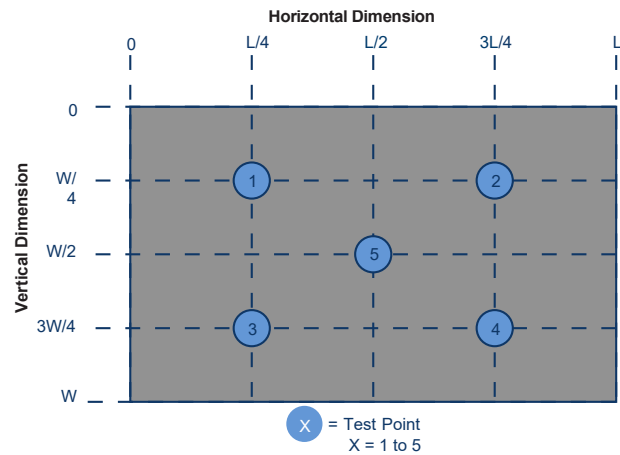
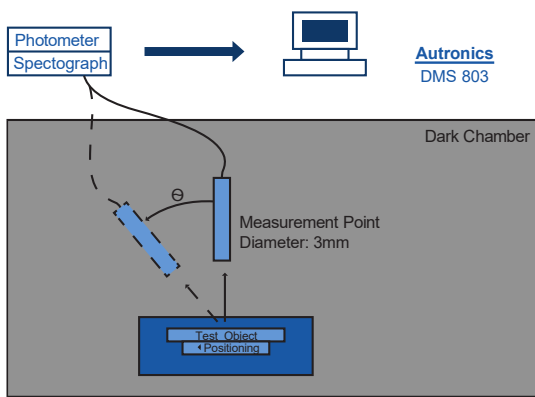

Fig. 1931 CIE Chromaticity Diagram

$$\text{Color Gamut: } S = \frac{\text{Area of RGB Triangle}}{\text{Area of NTSC Triangle}} \times 100\%$$

(6) Definition of Optical Measurement Setup:

The LCD module should be stabilized at a given temperature for 20 minutes to avoid abrupt temperature change during measuring. In order to stabilize the luminance, the measurement should be executed after lighting backlight for 20 minutes.



5. TFT Electrical Characteristics

5.1 Absolute Maximum Rating (Ta=25°C, VSS=0V)

Characteristics	Symbol	Min	Max	Unit
Digital Supply Voltage	VDD	-0.3	4.6	V
Supply Voltage (Logic)	IOVCC	-0.3	4.6	V
Operating Temperature	T _{OP}	-30	+80	°C
Storage Temperature	T _{ST}	-30	+85	°C

NOTE: If the absolute maximum rating of the above parameters is exceeded, even momentarily, the quality of the product may be degraded. Absolute maximum ratings specify the values which the product may be physically damaged if exceeded. Be sure to use the product within the range of the absolute maximum ratings.

5.2 DC Electrical Characteristics

Characteristics	Symbol	Min	Typ.	Max	Unit	Note
Digital Supply Voltage	VCC	2.4	3.3	3.6	V	--
Supply Voltage (Logic)	IOVCC	1.65	1.8	3.6	V	--
Normal Mode Current Consumption	IDD	--	6	12	mA	--
Level Input Voltage	V _{IH}	0.7*IOVCC	--	IOVCC	V	--
	V _{IL}	GND	--	0.3*IOVCC	V	--
Level Output Voltage	V _{OH}	0.8*IOVCC	--	IOVCC	V	--
	V _{OL}	GND	--	0.2*IOVCC	V	--

5.3 LED Backlight Characteristics

The backlight system is edge lighting type with 6 LED Chips

Item	Symbol	Min	Typ.	Max	Unit	Note
Forward Current	I_F	15	20	--	mA	--
Forward Voltage	V_F	--	19.2	--	V	--
LCM Luminance	L_V	120	150	--	cd/m ²	(3)
LED Lifetime	Hr	--	50000	--	hour	(1)(2)
Uniformity	Avg	80	--	--	%	(3)

Note 1: LED lifetime (Hr) can be defined as the time in which it continues to operate under the condition: $T_a=25 \pm 3^\circ\text{C}$, typical IL value indicated in the above table until the brightness becomes less than 50%.

Note 2: The "LED lifetime" is defined as the module brightness decrease to 50% original brightness at $T_a=25^\circ\text{C}$ and $I_F = 20\text{mA}$. The LED lifetime could be decreased if operating I_F is larger than 20mA. The constant current driving method is suggested.



BL CIRCUIT DIAGRAM

Note 3: Luminance Uniformity of these 9 points is defined as below:

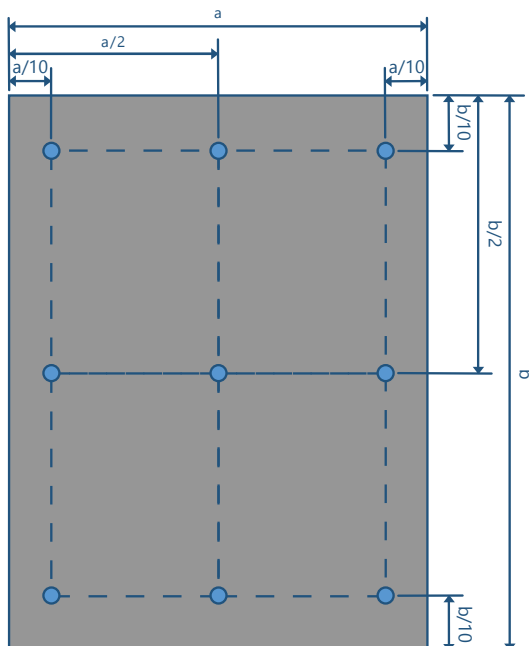

$$\text{Luminance} = \frac{(\text{Total Luminance of 9 Points})}{9}$$

$$\text{Uniformity} = \frac{\text{Minimum Luminance in 9 Points (1-9)}}{\text{Maximum Luminance in 9 Points (1-9)}}$$

6. TFT AC Characteristics

6.1 8080 Series MCU Parallel Interface Timing Characteristics: 18/16/9/8-bit Bus

For 8080 Series MCU parallel interface timing characteristics, diagrams and tables, see table and diagrams on pages 41-42 of the data sheet for controller ST7789V2. The data sheet can be found here: <https://focuslcs.com/wp-content/uploads/Drivers/ST7789V2.pdf>

6.2 Display Serial Interface Timing Characteristics (3-line serial):

For serial interface timing characteristics (3-line serial), diagrams and tables, see table and diagram page 43 of the data sheet for controller ST7789V2. The data sheet can be found here: <https://focuslcs.com/wp-content/uploads/Drivers/ST7789V2.pdf>

6.3 Display Serial Interface Timing Characteristics (4-line serial):

For serial interface timing characteristics (4-line serial), diagram and table, see the table and diagram page 44 of the data sheet for controller ST7789V2. The data sheet can be found here: <https://focuslcs.com/wp-content/uploads/Drivers/ST7789V2.pdf>

6.4 Parallel RGB Interface Timing Characteristics

For parallel RGB interface timing characteristics tables and diagram, see pages 46-47 of the data sheet for controller ST7789V2. The data sheet can be found here: <https://focuslcs.com/wp-content/uploads/Drivers/ST7789V2.pdf>

6.5 Reset Timing Characteristics

For the reset timing characteristics tables and diagrams, see pages 48-49 of the data sheet for controller ST7789V2. The data sheet can be found here: <https://focuslcs.com/wp-content/uploads/Drivers/ST7789V2.pdf>

7. CTP Electrical Characteristics

7.1 Absolute Maximum Rating

Item	Symbol	Min	Max	Unit	Note
Power Supply Voltage	VDD	-0.3	3.6	V	
Operating Temperature	T _{OP}	-20	+70	°C	
Storage Temperature	T _{ST}	-30	+80	°C	

7.2 DC Electrical Characteristics

Ambient temperature: 25°C

Item	Min	Typ.	Max	Unit	Note
Normal Mode Operating Current	--	9.8	--	mA	
Sleep Mode Operating Current	--	75	--	uA	
Monitor Mode Operating Current	--	0.5	--	mA	
Digital Input Low Voltage/V _{IL}	-0.3	--	0.3*VDDIO	V	
Digital Input High Voltage/V _{IH}	0.7*VDDIO	--	VDDIO	V	
Digital Output Low Voltage/V _{OL}	--	--	0.3*VDDIO	V	
Digital Output High Voltage/V _{OH}	0.7*VDDIO	--	--	V	

7.3 AC Characteristics

Ambient temperature: 25°C, VDD=2.8V

Parameter	Min	Typ.	Max	Unit
OSC Oscillation Frequency	47.04	48.00	48.96	MHZ

7.4 I2C Timing Characteristics

For I2C timing characteristics table, see table on page 7 of the data sheet for touch panel IC FT5446. The data sheet for the FT5446 can be found here:

<https://focuslcds.com/wp-content/uploads/Drivers/FT5446.pdf>

7.5 Power-On and Reset Timings

For power on and reset sequence timing diagrams, see diagrams and tables on pages 10-11 of the data sheet for touch panel IC FT5446. The data sheet for the FT5446 can be found here:

<https://focuslcds.com/wp-content/uploads/Drivers/FT5446.pdf>

8. Quality Inspection Standards

For TFT quality inspection standards, please see the following link:
<https://focuslcds.com/lcd-resources/tft-quality-inspection-standards/>

9. Cautions and Handling Precautions

9.1 Handling and Operating the Module

1. When the module is assembled, it should be attached to the system firmly. Do not warp or twist the module during assembly work.
2. Protect the module from physical shock or any force. In addition to damage, this may cause improper operation or damage to the module and back-light unit.
3. Note that polarizer is very fragile and could be easily damaged. Do not press or scratch the surface.
4. Do not allow drops of water or chemicals to remain on the display surface. If you have the droplets for a long time, staining and discoloration may occur.
5. If the surface of the polarizer is dirty, clean it using some absorbent cotton or soft cloth.
6. The desirable cleaners are water, IPA (Isopropyl Alcohol) or Hexane. Do not use ketene type materials (ex. Acetone), Ethyl alcohol, Toluene, Ethyl acid or Methyl chloride. It might permanent damage to the polarizer due to chemical reaction.
7. If the liquid crystal material leaks from the panel, it should be kept away from the eyes or mouth. In case of contact with hands, legs, or clothes, it must be washed away thoroughly with soap.
8. Protect the module from static; it may cause damage to the CMOS ICs.
9. Use fingerstalls with soft gloves in order to keep display clean during the incoming inspection and assembly process.
10. Do not disassemble the module.
11. Protection film for polarizer on the module shall be slowly peeled off just before use so that the electrostatic charge can be minimized.
12. Pins of I/F connector shall not be touched directly with bare hands.
13. Do not connect, disconnect the module in the "Power ON" condition.
14. Power supply should always be turned on/off by the item Power On Sequence & Power Off Sequence.

9.2 Storage and Transportation

1. Do not leave the panel in high temperature, and high humidity for a long time. It is highly recommended to store the module with temperature from 0 to 35°C and relative humidity of less than 70%.
2. Do not store the TFT-LCD module in direct sunlight.
3. The module shall be stored in a dark place. When storing the modules for a long time, be sure to adopt effective measures for protecting the modules from strong ultraviolet radiation, sunlight, or fluorescent light.
4. It is recommended that the modules should be stored under a condition where no condensation is allowed. Formation of dewdrops may cause an abnormal operation or a failure of the module. In particular, the greatest possible care should be taken to prevent any module from being operated where condensation has occurred inside.
5. This panel has its circuitry FPC on the bottom side and should be handled carefully in order not to be stressed.