



FOCUS LCDs

LCDs MADE SIMPLE[®]



ISO 9001

QUALITY
MANAGEMENT

MEDICAL | INDUSTRIAL | DEFENSE | AGRICULTURE | FOOD SERVICE

E30RC-I-MW350-CB

Product Description

- 3.0-inch TFT (36.96x90.08mm)
- 268x800 Pixels
- 2-Lane MIPI
- Wide Temperature Range
- All Viewing Angles

- IPS, Transmissive
- Capacitive Touch Panel
- 350 NITS
- TFT IC: ST7701, CTP IC: GT911
- RoHS Compliant

Revision History

Date	Rev. No	Page	Summary
06/09/2022	1.0	All	First issue

Description

This is a color active matrix TFT (Thin Film Transistor) LCD (Liquid Crystal Display) that uses amorphous silicon TFT as a switching device. This model is composed of a transmissive type TFT-LCD Panel, driver circuit, capacitive touch panel, and backlight unit. The resolution of the 3.0" TFT-LCD contains 268x800 pixels and can display up to 16.7M colors.

Features

Input Voltage: 2.8V

TFT Interface: 2-Lane MIPI

CTP Interface: I2C

General Information Items	Specification	Unit	Note
	Main Panel		
TFT Display Area (AA)	24.12(H) x 72.00(V) (3.0 inch)	mm	--
CTP View Area	24.72(H) x 72.60(V)	mm	--
Driver Element	TFT active matrix	--	--
Display Colors	16.7M	colors	--
Number of Pixels	268(RGB)x800	dots	--
TFT Pixel Arrangement	RGB vertical stripe	--	--
Pixel Pitch	0.09 (H) x 0.09 (V)	mm	--
Viewing Angle	ALL	o'clock	--
TFT Controller IC	ST7701	--	--
CTP Driver IC	GT911	--	--
Display Mode	Transmissive/Normally Black	--	--
Touch Points	5 points	--	--
Operating Temperature	-20 to +70	°C	--
Storage Temperature	-30 to +80	°C	--

Mechanical Information

Item		Min.	Typ.	Max.	Unit	Note
Module Size	Horizontal (H)	--	36.96	--	mm	--
	Vertical (V)	--	90.08	--	mm	--
	Depth (D)	--	2.79	--	mm	--
Weight		--	15	--	g	Approximate

1. Outline Dimensions

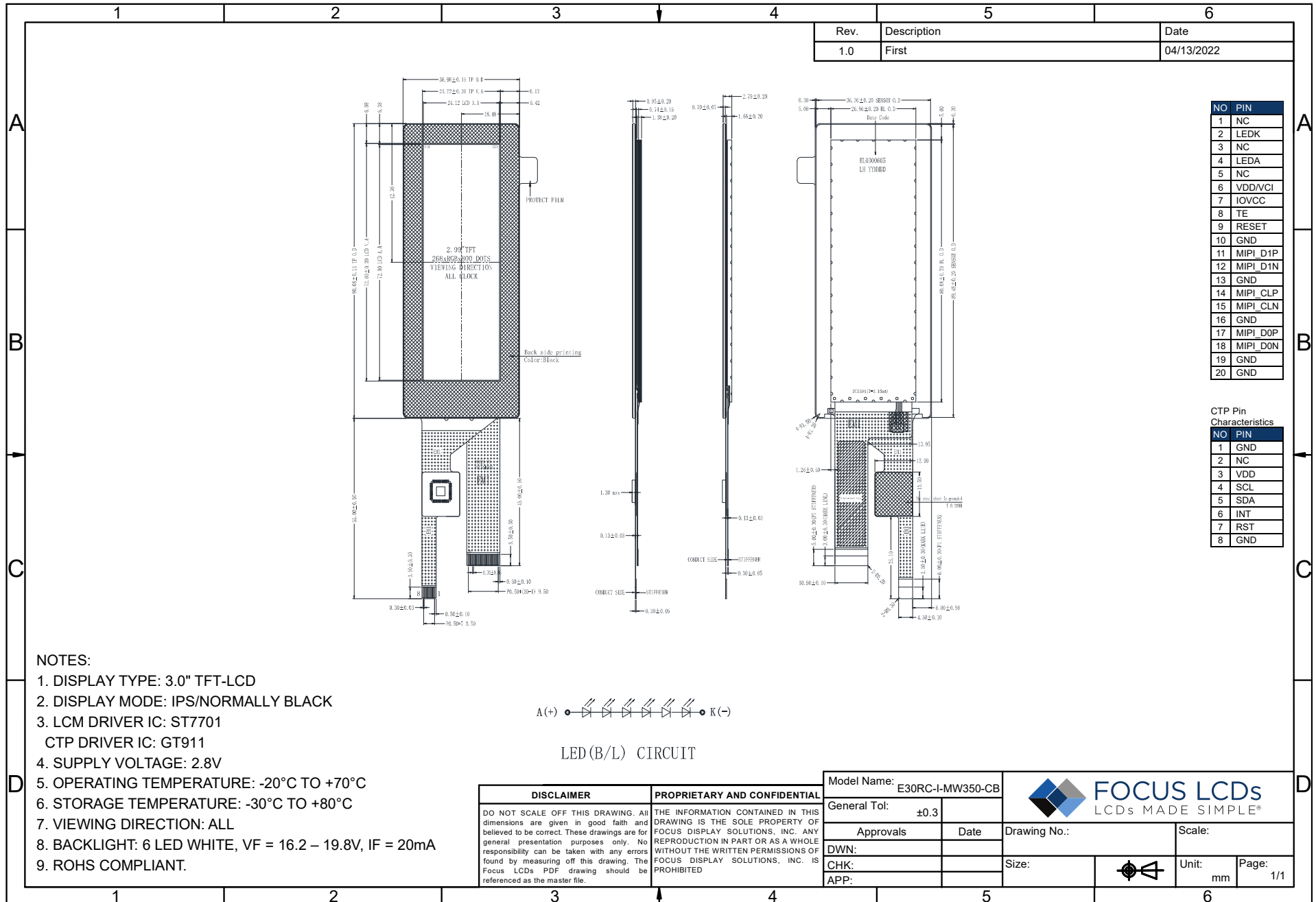

2. Block Diagram

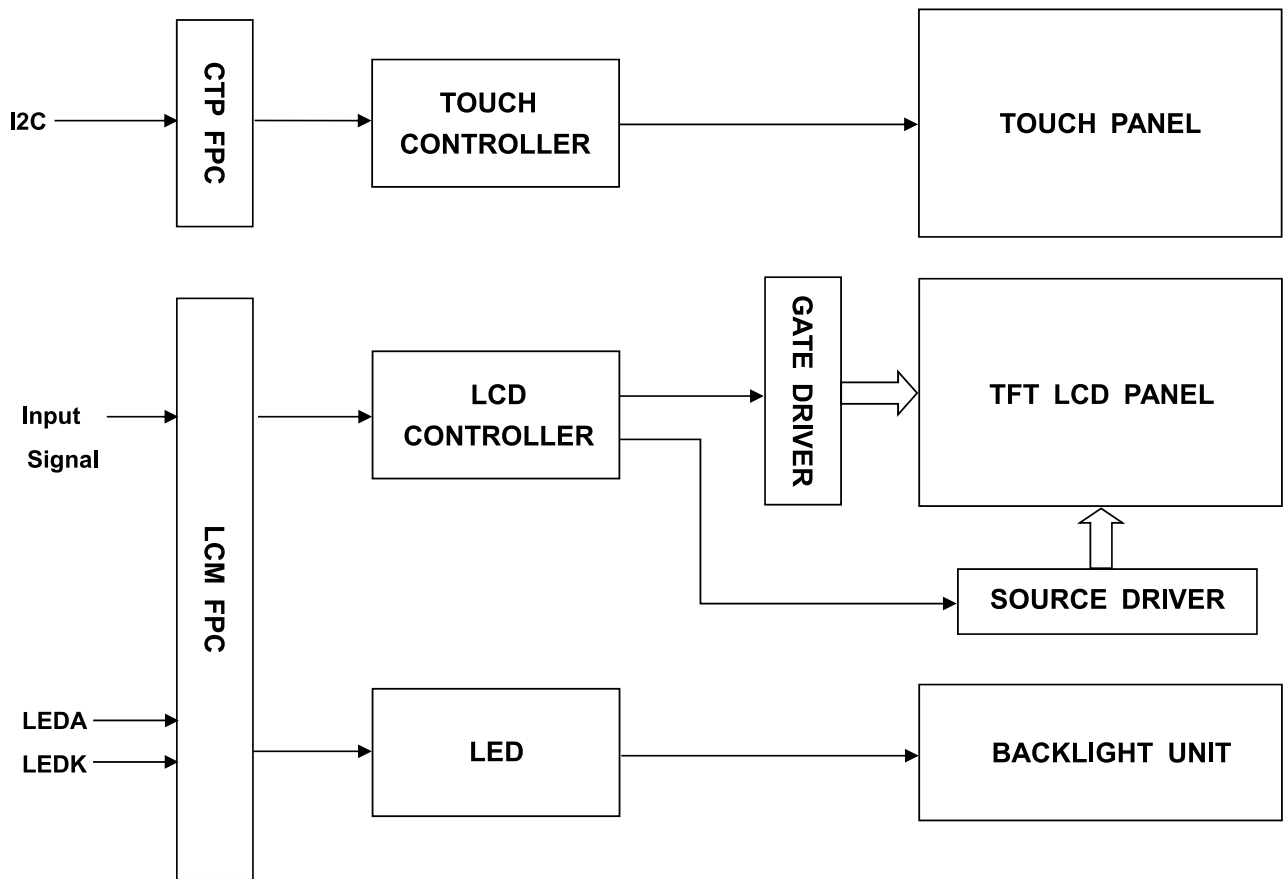

3. Input Terminal Pin Assignment

3.1 TFT Pin Assignment

NO.	Symbol	Description	I/O
1	NC	No connection.	--
2	LEDK	Cathode pin of backlight.	P
3	NC	No connection.	--
4	LEDA	Anode pin of backlight.	P
5	NC	No connection.	--
6	VDD/VCI	Power supply for analog circuits.	P
7	IOVCC	I/O power supply voltage.	P
8	TE	Tearing effect output. Leave the pin to open when not in use.	O
9	RESET	The external reset input. Initializes the chip with a low input. Be sure to execute a power-on reset after supplying power. Fix to IOVCC level when not in use.	I
10	GND	Ground.	P
11	MIPI_D1P	MIPI DSI differential data pair (Data lane 1).	I/O
12	MIPI_D1N		
13	GND	Ground.	P
14	MIPI_CLP	MIPI DSI differential data pair.	I
15	MIPI_CLN		
16	GND	Ground.	P
17	MIPI_D0P	MIPI DSI differential data pair (Data lane 0).	I/O
18	MIPI_D0N		
19	GND	Ground.	P
20	GND	Ground.	P

3.2 CTP Pin Assignment

NO.	Symbol	Description	I/O
1	GND	Ground.	P
2	NC	No connection.	--
3	VDD	Supply voltage.	P
4	SCL	I2C clock input.	I
5	SDA	I2C data input and output.	I/O
6	INT	External interrupt to the host.	I
7	RST	External reset. Low is active.	I
8	GND	Ground.	P

4. LCD Optical Characteristics

4.1 Optical Specifications

Item	Symbol	Condition	Min	Typ.	Max	Unit	Note
Color Gamut	S(%)		50.00	54.40	--	%	(5)
Contrast Ratio	CR		800	1000	--	%	(2)
Response Time	Rising	T_R	--	30	40	ms	(4)
	Falling	T_F					
Color Filter Chromaticity	White	W_X	$\theta=0$ Normal viewing angle	0.2420	0.2820	0.3220	(5)(6)
		W_Y					
	Red	R_X					
		R_Y					
	Green	G_X					
		G_Y					
	Blue	B_X					
		B_Y					
Viewing Angle	Hor.	Θ_L	CR \geq 10	--	80	--	degree
		Θ_R					
	Ver.	Θ_T					
		Θ_B					
Option View Direction			ALL				(1)

Measuring Conditions:

1. Dark Room
2. Ambient Temperature of 25 \pm 2°C
3. 15 Minute Warm up

Optical Specification Reference Notes:

(1) Definition of Viewing Angle:

The viewing angle is the angle at which the contrast ratio is greater than 10. The viewing angles are determined for the horizontal or 3,9 o'clock direction and the vertical or 6,12 o'clock direction with respect to the optical axis which is normal to the LCD surface.

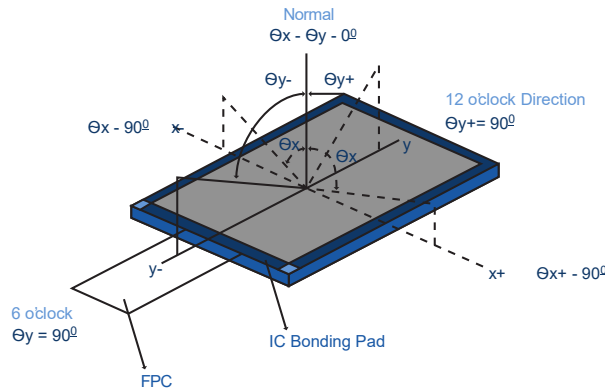

(2) Definition of Contrast Ratio:

Measured at the center point of panel. The contrast ratio (Cr) measured on a module, is the ratio between the luminance (Lw) in a full white area (R=G=B=1) and the luminance (Ld) in a dark area (R=G=B=0).

$$Cr = \frac{L_w}{L_d}$$

(3) Definition of Transmittance (T%):

The transmittance of the panel including the polarizers is measured with electrical driving. The equation for transmittance Tr is:

$$Tr = \frac{I_t}{I_o} \times 100\%$$

I_o = the brightness of the light source.

I_t = the brightness after panel transmission

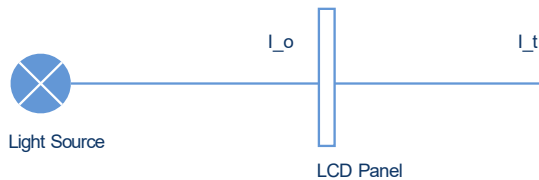

(4) Definition of Response Time (TR, TF):

The rise time 'Tr' is defined as the time for luminance to change from 90% to 10% as a result of a change of the electrical condition. The fall time 'Tf' is defined as the time for luminance to change from 10% to 90% as a result of a change of the electrical condition.

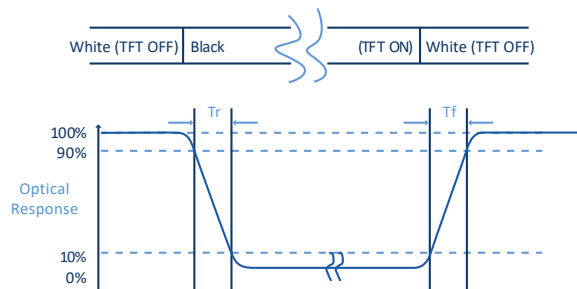

(5) Definition of Color Gamut:

Measuring machine CFT-01. NTSC's Primaries: $R(x,y,Y)$, $G(x,y,Y)$, $B(x,y,Y)$. FPM520 of Westar Display Technologies, INC., which utilized SR-3 for Chromaticity and BM-5A for other optical characteristics. The color chromaticity shall be calculated from the spectral data measured with all pixels first in red, green, blue and white. Measurements shall be made at the center of the panel.

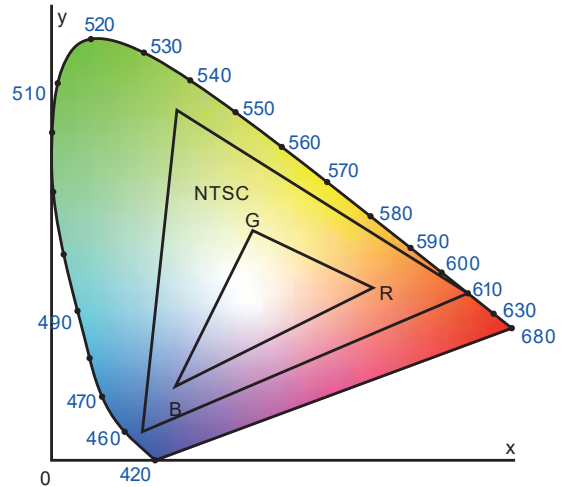
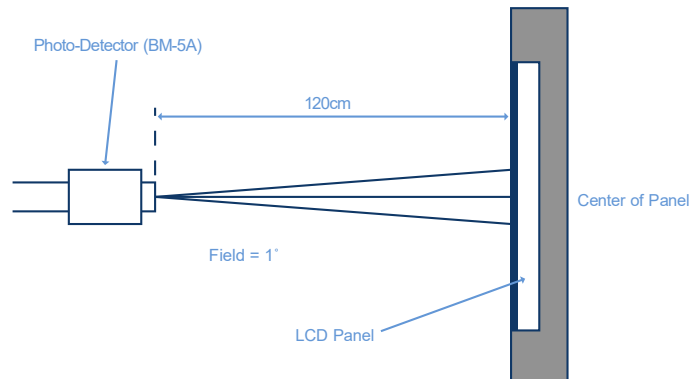
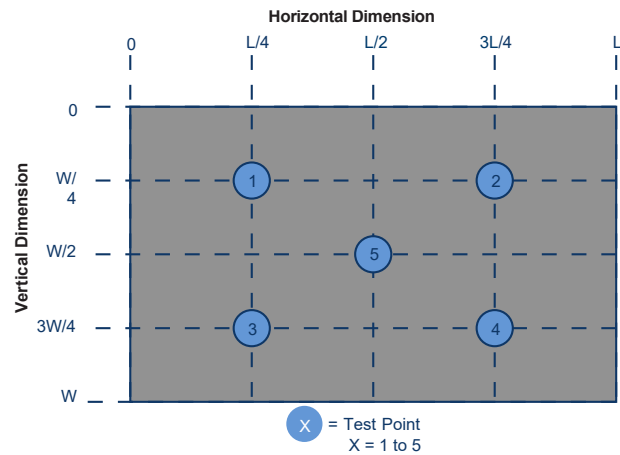
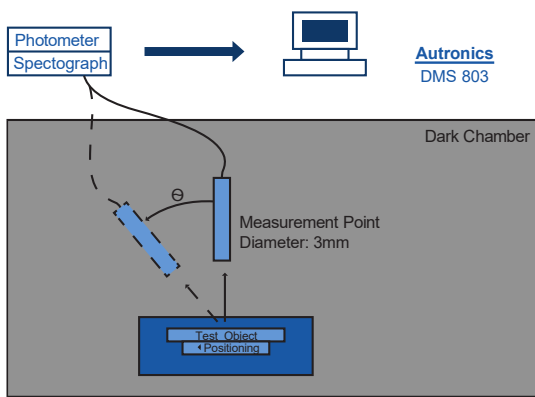

Fig. 1931 CIE Chromaticity Diagram

$$\text{Color Gamut: } S = \frac{\text{Area of RGB Triangle}}{\text{Area of NTSC Triangle}} \times 100\%$$

(6) Definition of Optical Measurement Setup:

The LCD module should be stabilized at a given temperature for 20 minutes to avoid abrupt temperature change during measuring. In order to stabilize the luminance, the measurement should be executed after lighting backlight for 20 minutes.



5. TFT Electrical Characteristics

5.1 Absolute Maximum Rating (Ta=25°C, VSS=0V)

Characteristics	Symbol	Min	Max	Unit
Digital Supply Voltage	VDD/VCI	-0.3	4.6	V
Supply Voltage (Logic)	IOVCC	-0.3	4.6	V
Operating Temperature	T _{OP}	-20	+70	°C
Storage Temperature	T _{ST}	-30	+80	°C

NOTE: If the absolute maximum rating of the above parameters is exceeded, even momentarily, the quality of the product may be degraded. Absolute maximum ratings specify the values which the product may be physically damaged if exceeded. Be sure to use the product within the range of the absolute maximum ratings.

5.2 DC Electrical Characteristics

Characteristics	Symbol	Min	Typ.	Max	Unit	Note
Digital Supply Voltage	VDD/VCI	2.5	2.8	3.6	V	--
Supply Voltage (Logic)	IOVCC	1.65	1.8	3.3	V	--
Normal Mode Current Consumption	IDD	--	33	65	mA	--
Level Input Voltage	V _{IH}	0.7*IOVCC	--	IOVCC	V	--
	V _{IL}	GND	--	0.3*IOVCC	V	--
Level Output Voltage	V _{OH}	0.8*IOVCC	--	IOVCC	V	--
	V _{OL}	GND	--	0.2*IOVCC	V	--

5.3 LED Backlight Characteristics

The backlight system is edge lighting type with 6 LED Chips

Item	Symbol	Min	Typ.	Max	Unit	Note
Forward Current	I_F	--	20	--	mA	--
Forward Voltage	V_F	--	16.2	--	V	--
LCM Luminance	L_V	300	350	--	cd/m ²	(3)
LED Lifetime	Hr	50000	--	--	hour	(1)(2)
Uniformity	Avg	80	--	--	%	(3)

Note 1: LED lifetime (Hr) can be defined as the time in which it continues to operate under the condition: $T_a=25 \pm 3^\circ\text{C}$, typical I_L value indicated in the above table until the brightness becomes less than 50%.

Note 2: The "LED lifetime" is defined as the module brightness decrease to 50% original brightness at $T_a=25^\circ\text{C}$ and $I_F = 20\text{mA}$. The LED lifetime could be decreased if operating I_F is larger than 20mA. The constant current driving method is suggested.

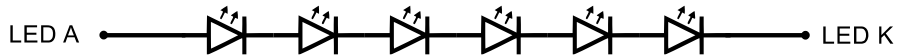

BL CIRCUIT DIAGRAM

Note 3: Luminance Uniformity of these 9 points is defined as below:

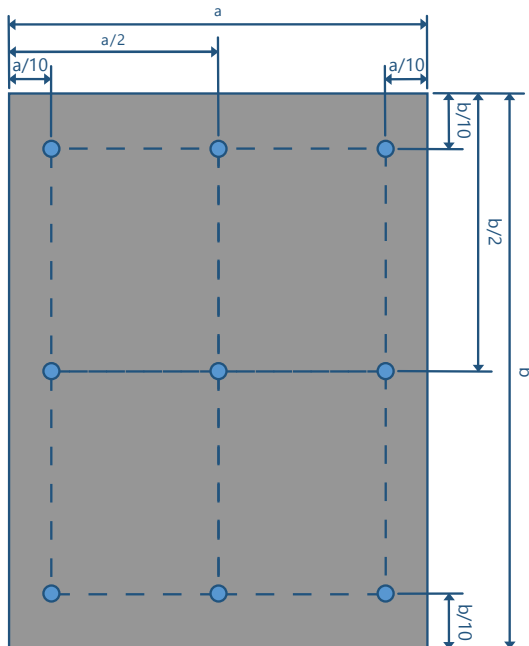

$$\text{Luminance} = \frac{(\text{Total Luminance of 9 Points})}{9}$$

$$\text{Uniformity} = \frac{\text{Minimum Luminance in 9 Points (1-9)}}{\text{Maximum Luminance in 9 Points (1-9)}}$$

6. TFT AC Characteristics

6.1 High Speed Data Transmission: Data-Clock Timing

For high speed data transmission clock-lane timing diagrams and table, see page 50 of the data sheet for controller IC ST7701. The data sheet can be found here:

<https://focuslcds.com/wp-content/uploads/Drivers/ST7701.pdf>

6.2 High Speed Data Transmission

For high speed data transmission diagrams, see page 96 of the data sheet for controller IC ST7701. The data sheet can be found here: <https://focuslcds.com/wp-content/uploads/Drivers/ST7701.pdf>

6.3 Turnaround Procedure

For turnaround procedure diagrams, see diagrams on page 100 of the data sheet for controller IC ST7701. The data sheet can be found here:

<https://focuslcds.com/wp-content/uploads/Drivers/ST7701.pdf>

6.4 Switching the Clock Lane Between Clock Transmission and Low-Power Mode

For switching the clock lane between high speed clock mode, low-power mode, and ultra-low power mode tables and diagrams, see pages 82-87 of the data sheet for controller IC ST7701. The data sheet can be found here: <https://focuslcds.com/wp-content/uploads/Drivers/ST7701.pdf>

6.5 Reset Timing Characteristics

For the reset timing characteristics table and diagram, see page 54 for the data sheet for controller IC ST7701. The data sheet can be found here:

<https://focuslcds.com/wp-content/uploads/Drivers/ST7701.pdf>

7. CTP Electrical Characteristics

7.1 Absolute Maximum Rating

Item	Symbol	Min	Max	Unit	Note
Power Supply Voltage	VDD	2.66	3.47	V	
Operating Temperature	T _{OP}	-20	+70	°C	
Storage Temperature	T _{ST}	-30	+80	°C	

7.2 DC Electrical Characteristics

Ambient temperature: 25°C, AVDD=2.8V, VDDIO=1.8V or VDDIO=AVDD

Item	Min	Typ.	Max	Unit	Note
Normal Mode Operating Current	--	8	14.5	mA	
Green Mode Operating Current	--	3.3	--	mA	
Sleep Mode Operating Current	70	--	120	uA	
Doze Mode Operating Current	--	0.78	--	mA	
Digital Input Low Voltage/V _{IL}	-0.3	--	0.25*VDD	V	
Digital Input High Voltage/V _{IH}	0.75*VDD	--	VDD+0.3	V	
Digital Output Low Voltage/V _{OL}	--	--	0.15*VDD	V	
Digital Output High Voltage/V _{OH}	0.85*VDD	--	--	V	

7.3 AC Characteristics

Ambient temperature: 25°C, AVDD=2.8V, VDDIO=1.8V

Parameter	Min	Typ.	Max	Unit
OSC Oscillation Frequency	59	60	61	MHZ
I/O Output Rise Time, Low to High	--	14	--	ns
I/O Output Fall Time, High to Low	--	14	--	ns

7.4 I2CTiming

For I2C timing diagrams and tables, see page 9 of the data sheet for touch panel IC GT911. The data sheet for GT911 can be found here: <https://focuslcds.com/content/GT911.pdf>

7.5 Power-On Timing

For the power on timing diagram, see the first diagram on page 10 of the data sheet for touch panel IC GT911. The data sheet for GT911 can be found here: <https://focuslcds.com/content/GT911.pdf>

7.6 Timing for Host Resetting GT911

For the host resetting timing diagram, see the second diagram on page 10 of the data sheet for touch panel IC GT911. The data sheet for GT911 can be found here: <https://focuslcds.com/content/GT911.pdf>

7.7 Timing for Setting Slave Address to 0x28/0x29

For this setting slave address timing diagram, see the third diagram on page 10 of the data sheet for touch panel IC GT911. The data sheet for GT911 can be found here: <https://focuslcds.com/content/GT911.pdf>

7.8 Timing for Setting Slave Address to 0xBA/0xBB

For this setting slave address timing diagram and instructions, see pages 11-12 of the data sheet for touch panel IC GT911. The data sheet for GT911 can be found here: <https://focuslcds.com/content/GT911.pdf>

8. Quality Inspection Standards

For TFT quality inspection standards, please see the following link: <https://focuslcds.com/lcd-resources/tft-quality-inspection-standards/>

9. Cautions and Handling Precautions

9.1 Handling and Operating the Module

1. When the module is assembled, it should be attached to the system firmly. Do not warp or twist the module during assembly work.
2. Protect the module from physical shock or any force. In addition to damage, this may cause improper operation or damage to the module and back-light unit.
3. Note that polarizer is very fragile and could be easily damaged. Do not press or scratch the surface.
4. Do not allow drops of water or chemicals to remain on the display surface. If you have the droplets for a long time, staining and discoloration may occur.
5. If the surface of the polarizer is dirty, clean it using some absorbent cotton or soft cloth.
6. The desirable cleaners are water, IPA (Isopropyl Alcohol) or Hexane. Do not use ketene type materials (ex. Acetone), Ethyl alcohol, Toluene, Ethyl acid or Methyl chloride. It might permanent damage to the polarizer due to chemical reaction.
7. If the liquid crystal material leaks from the panel, it should be kept away from the eyes or mouth. In case of contact with hands, legs, or clothes, it must be washed away thoroughly with soap.
8. Protect the module from static; it may cause damage to the CMOS ICs.
9. Use fingerstalls with soft gloves in order to keep display clean during the incoming inspection and assembly process.
10. Do not disassemble the module.
11. Protection film for polarizer on the module shall be slowly peeled off just before use so that the electrostatic charge can be minimized.
12. Pins of I/F connector shall not be touched directly with bare hands.
13. Do not connect, disconnect the module in the "Power ON" condition.
14. Power supply should always be turned on/off by the item Power On Sequence & Power Off Sequence.

9.2 Storage and Transportation

1. Do not leave the panel in high temperature, and high humidity for a long time. It is highly recommended to store the module with temperature from 0 to 35°C and relative humidity of less than 70%.
2. Do not store the TFT-LCD module in direct sunlight.
3. The module shall be stored in a dark place. When storing the modules for a long time, be sure to adopt effective measures for protecting the modules from strong ultraviolet radiation, sunlight, or fluorescent light.
4. It is recommended that the modules should be stored under a condition where no condensation is allowed. Formation of dewdrops may cause an abnormal operation or a failure of the module. In particular, the greatest possible care should be taken to prevent any module from being operated where condensation has occurred inside.
5. This panel has its circuitry FPC on the bottom side and should be handled carefully in order not to be stressed.