



FOCUS LCDs
LCDs MADE SIMPLE®

Ph. 480-503-4295 | LCD@FocusLCDs.com

TFT | OLED | CHARACTER | GRAPHIC | UWVD | SEGMENT | CUSTOM

TFT Display Module

Part Number

E35RB-I-XS350-N

Overview:

- 3.5-inch TFT (63.00x85.00mm)
- 240x320 Pixels
- 8/16/18-Bit MCU, 3-SPI+16/18-Bit RGB, 3-line Serial Interface
- Special Temperature Range
- All Viewing Angles
- Transmissive
- No Touch Panel
- 350 NITS
- TFT IC: HX8347A
- RoHS Compliant

Description

This is a color active matrix TFT (Thin Film Transistor) LCD (Liquid Crystal Display) that uses amorphous silicon TFT as a switching device. This model is composed of a transmissive type TFT- LCD Panel, driver circuit, and backlight unit. The resolution of the 3.5" TFT- LCD contains 240x320 pixels and can display up to 65K/262K colors.

Features

Input Voltage: 3.3V

TFT Interface: 8/16/18-Bit MCU, 3-SPI+16/18-Bit RGB, 3-line Serial Interface

General Information Items	Specification	Unit	Note
	Main Panel		
TFT Display Area (AA)	53.28(H) x 71.04(V) (3.5 inch)	mm	--
Driver Element	TFT active matrix	--	--
Display Colors	65K/262K	colors	--
Number of Pixels	240(RGB)x320	dots	--
TFT Pixel Arrangement	RGB vertical stripe	--	--
Pixel Pitch	0.222 (H) x 0.222 (V)	mm	--
Viewing Angle	ALL	o'clock	--
TFT Controller IC	HX8347A	--	--
Display Mode	Transmissive/Normally Black	--	--
Operating Temperature	-30 to +85	°C	--
Storage Temperature	-40 to +90	°C	--

Mechanical Information

Item		Min.	Typ.	Max.	Unit	Note
Module Size	Horizontal (H)	--	63.00	--	mm	--
	Vertical (V)	--	85.00	--	mm	--
	Depth (D)	--	3.00	--	mm	--
Weight		--	TBD	--	g	--

1. Outline Dimensions

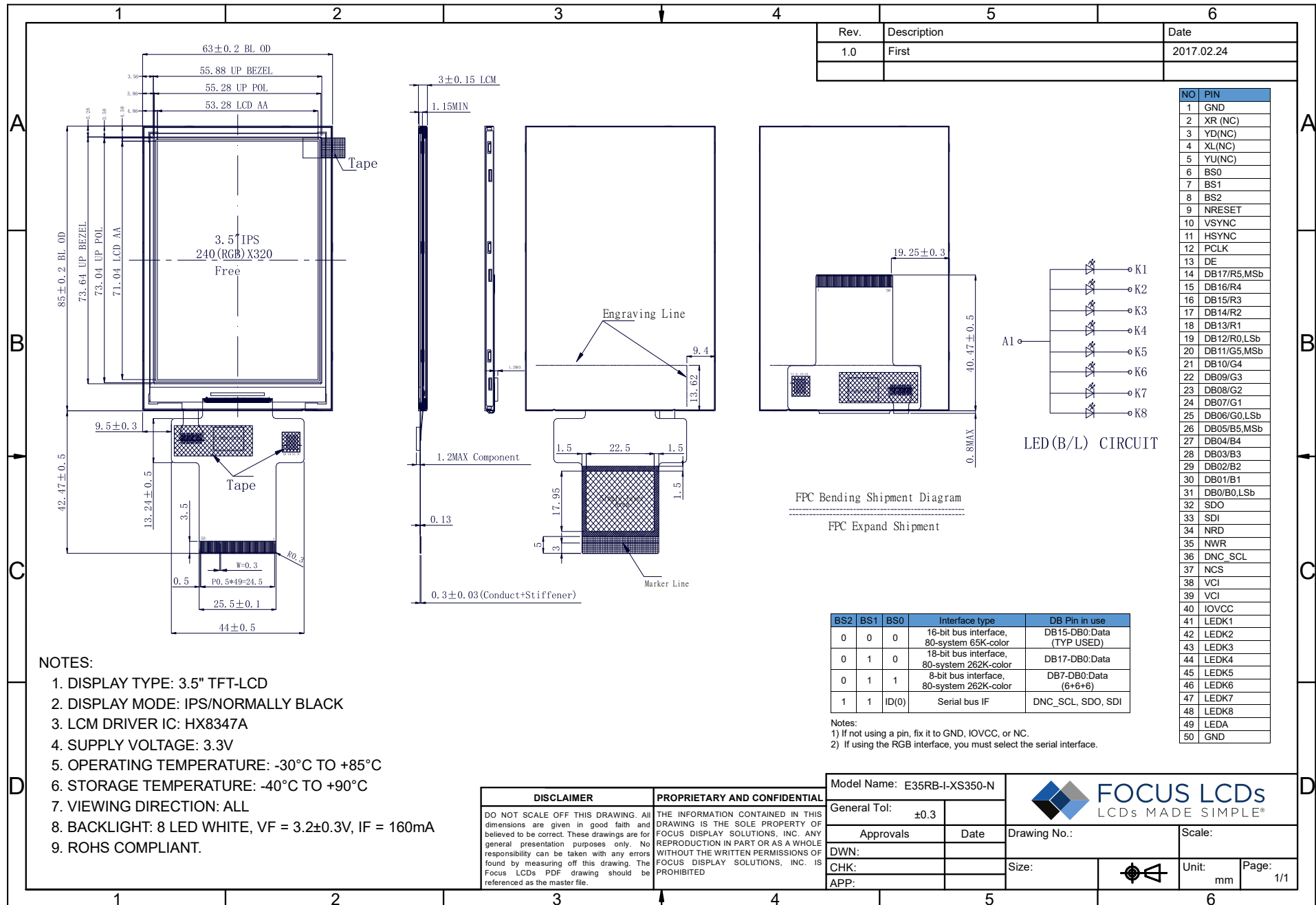

2. Block Diagram

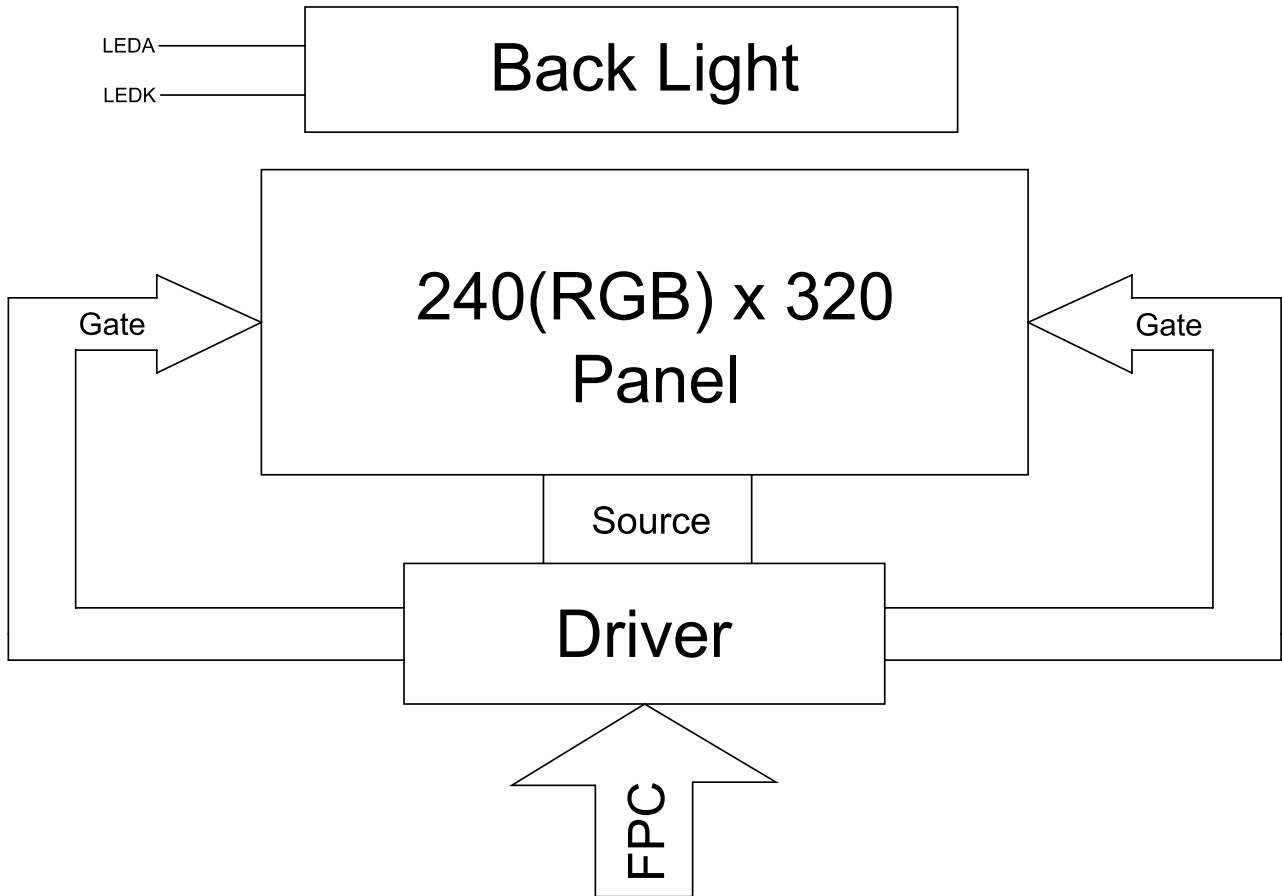

3. Input Terminal Pin Assignment

3.1 TFT Pin Assignment

Recommended TFT Connector: 5027905091

NO.	Symbol	Description	I/O
1	GND	Ground.	P
2	XR(NC)	Touch panel right glass terminal.	A/D
3	YD(NC)	Touch panel bottom film terminal.	A/D
4	XL(NC)	Touch panel left glass terminal.	A/D
5	YU(NC)	Touch panel top film terminal.	A/D
6	BS0	MPU parallel interface bus and serial interface selection. If using the RGB interface, you must select the serial interface. Fix this pin at VCI or GND when not in use.	I
7	BS1		
8	BS2		
9	NRESET	This signal will reset the device and must be applied to properly initialize the chip.	I
10	VSYNC	Frame synchronizing signal for RGB interface operation. Fix this pin at VCI or GND when not in use.	I
11	HSYNC	Line synchronizing signal for RGB interface operation. Fix this pin at VCI or GND when not in use.	I
12	PCLK	Dot clock signal for RGB interface operation. Fix this pin at VCI or GND when not in use.	I
13	DE	Data enable signal for RGB interface operation. Fix this pin at VCI or GND when not in use.	I
14-31	DB17-DB0	18-bit parallel bi-directional data bus for MCU system and RGB interface mode. Fix to GND level when not in use.	I
32	SDO	Serial data output pin in the serial bus system interface. If not used, please open this pin.	O
33	SDI	Serial input signal. The data is applied on the rising edge of the SCL signal. If not used, fix this pin at VCI or GND.	I
34	NRD	Serves as a read signal and MCU read data at the rising edge. Fix this pin at VCI or GND when not in use.	I
35	NWR	NWR pin, serves as a write signal.	I
36	DNC_SCL	DNC_SCL pin as serial clock when operates in the serial interface.	I
37	NCS	Chip select input pin ("Low" enable). Fix this pin at VCI or GND when not in use.	I
38	VCI	Supply voltage (3.3V).	P
39	VCI	Supply voltage (3.3V).	P
40	IOVCC	Supply voltage (1.8-3.3V).	P
41	LEDK1	Backlight cathode pin.	P
42	LEDK2	Backlight cathode pin.	P
43	LEDK3	Backlight cathode pin.	P
44	LEDK4	Backlight cathode pin.	P
45	LEDK5	Backlight cathode pin.	P
46	LEDK6	Backlight cathode pin.	P
47	LEDK7	Backlight cathode pin.	P
48	LEDK8	Backlight cathode pin.	P

49	LEDA	Backlight anode pin.	P
50	GND	Ground.	P

I: Input, O: Output, P: Power

4. LCD Optical Characteristics

4.1 Optical Specifications

Item	Symbol	Condition	Min	Typ.	Max	Unit	Note	
Color Gamut	S(%)		--	72	--	%	(5)	
Contrast Ratio	CR		--	800	--	%	(2)	
Response Time	Rising	TR		16	21	ms	(4)	
	Falling	TF		19	24			
Color Filter Chromaticity	White	WX	$\theta=0$ Normal viewing angle	0.3360	0.3400	0.3440	(5)(6)	
		WY		0.3560	0.3600	0.3640		
	Red	RX		0.6180	0.6200	0.6220		
		RY		0.3380	0.3400	0.3420		
	Green	GX		0.3480	0.3500	0.3520		
		GY		0.6200	0.6220	0.6240		
	Blue	BX		0.1480	0.1500	0.1520		
		BY		0.0330	0.0350	0.0370		
Viewing Angle	Hor.	Θ L	CR \geq 10	--	80	--	degree	(1)(6)
		Θ R		--	80	--		
	Ver.	Θ T		--	80	--		
		Θ B		--	80	--		
Option View Direction	ALL						(1)	

Measuring Conditions:

1. Dark Room
2. Ambient Temperature of 25 \pm 2°C
3. 15 Minute Warm up

Optical Specification Reference Notes:

(1) Definition of Viewing Angle:

The viewing angle is the angle at which the contrast ratio is greater than 10. The viewing angles are determined for the horizontal or 3,9 o'clock direction and the vertical or 6,12 o'clock direction with respect to the optical axis which is normal to the LCD surface.

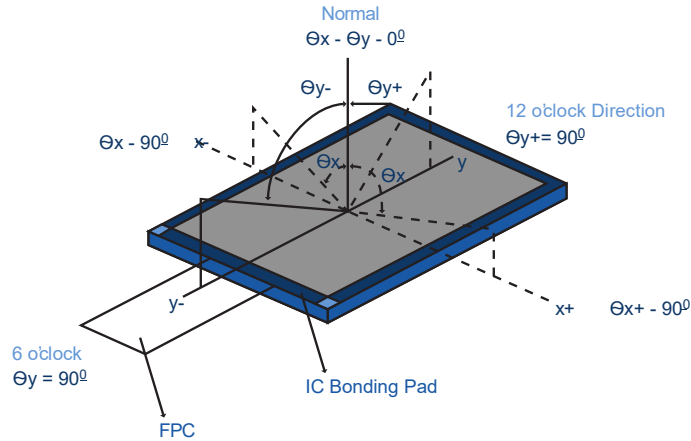

(2) Definition of Contrast Ratio:

Measured at the center point of panel. The contrast ratio (Cr) measured on a module, is the ratio between the luminance (Lw) in a full white area (R=G=B=1) and the luminance (Ld) in a dark area (R=G=B=0).

$$Cr = \frac{Lw}{Ld}$$

(3) Definition of Transmittance (T%):

The transmittance of the panel including the polarizers is measured with electrical driving. The equation for transmittance Tr is:

$$Tr = \frac{I_t}{I_o} \times 100\%$$

I_o = the brightness of the light source.

I_t = the brightness after panel transmission

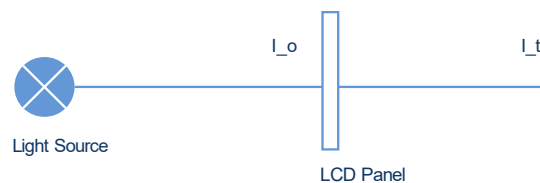

(4) Definition of Response Time (Tr, Tf):

The rise time 'Tr' is defined as the time for luminance to change from 90% to 10% as a result of a change of the electrical condition. The fall time 'Tf' is defined as the time for luminance to change from 10% to 90% as a result of a change of the electrical condition.

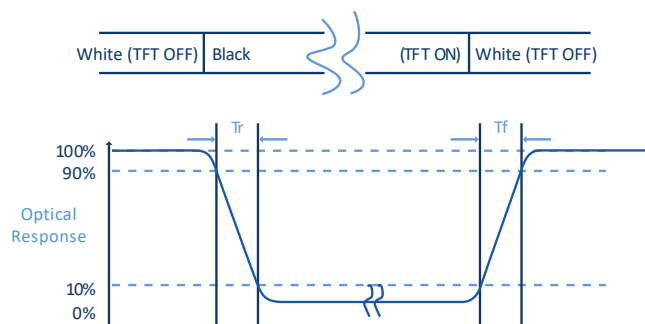

(5) Definition of Color Gamut:

Measuring machine CFT-01. NTSC's Primaries: R(x,y,Y),G(x,y,Y), B(x,y,Y). FPM520 of Westar Display Technologies, INC., which utilized SR-3 for Chromaticity and BM-5A for other optical characteristics. The color chromaticity shall be calculated from the spectral data measured with all pixels first in red, green, blue and white. Measurements shall be made at the center of the panel.

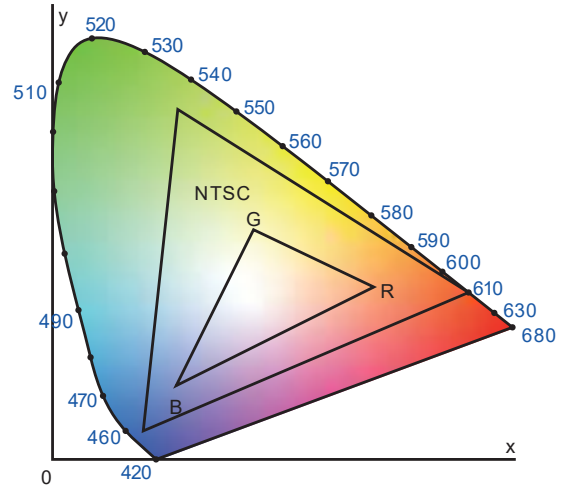
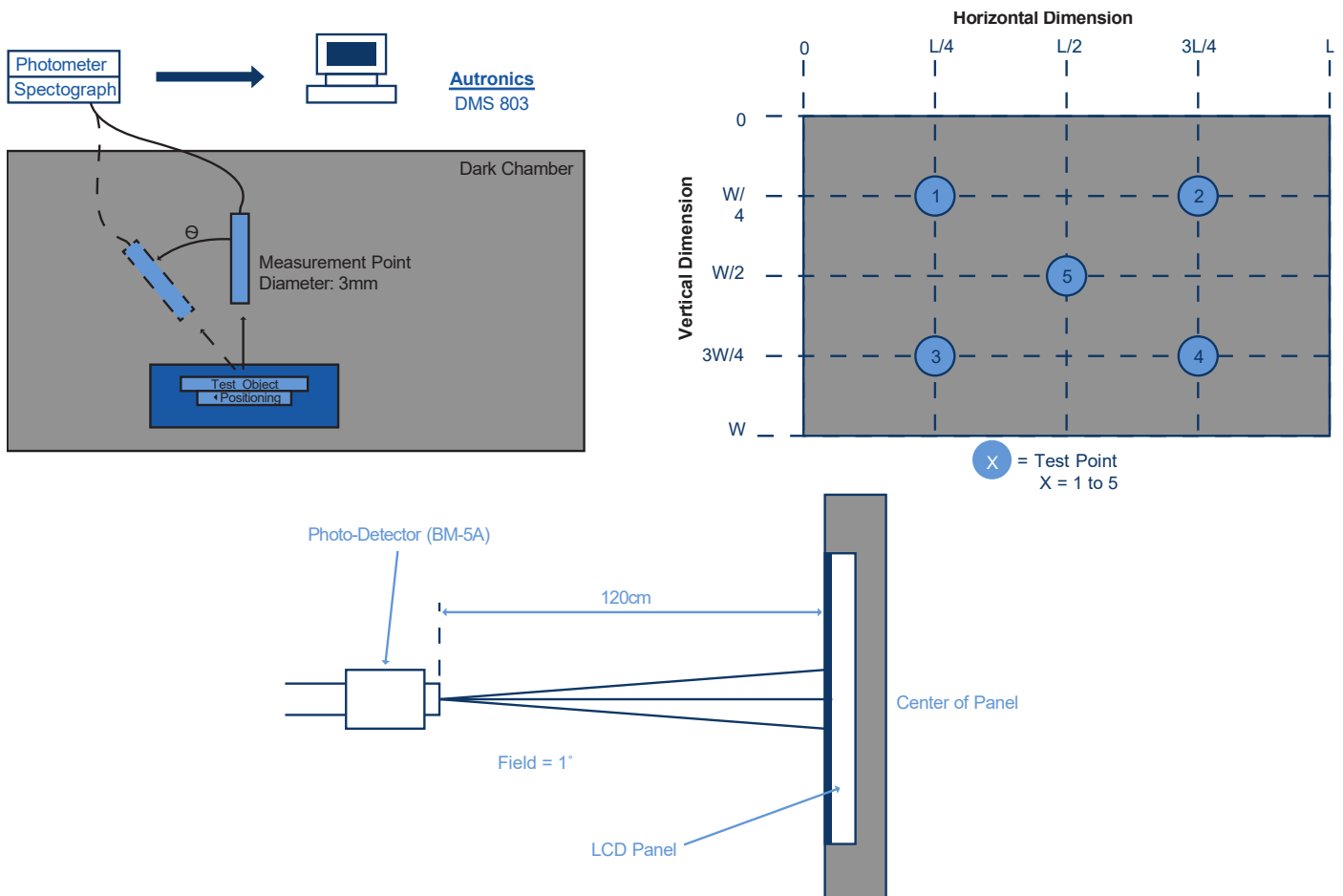

Fig. 1931 CIE Chromaticity Diagram

$$\text{Color Gamut: } S = \frac{\text{Area of RGB Triangle}}{\text{Area of NTSC Triangle}} \times 100\%$$

(6) Definition of Optical Measurement Setup:

The LCD module should be stabilized at a given temperature for 20 minutes to avoid abrupt temperature change during measuring. In order to stabilize the luminance, the measurement should be executed after lighting backlight for 20 minutes.



5. TFT Electrical Characteristics

5.1 Absolute Maximum Rating (Ta=25°C, VSS=0V)

Characteristics	Symbol	Min	Max	Unit
Digital Supply Voltage	V _{CI}	-0.3	4.2	V
Supply Voltage (Logic)	IOVCC	-0.3	3.3	V
Operating Temperature	T _{OP}	-30	+85	°C
Storage Temperature	T _{ST}	-40	+90	°C

NOTE: If the absolute maximum rating of the above parameters is exceeded, even momentarily, the quality of the product may be degraded. Absolute maximum ratings specify the values which the product may be physically damaged if exceeded. Be sure to use the product within the range of the absolute maximum ratings.

5.2 DC Electrical Characteristics

Characteristics	Symbol	Min	Typ.	Max	Unit	Note
Digital Supply Voltage	V _{CI}	2.5	2.8	3.3	V	--
Supply Voltage (Logic)	IOVCC	1.65	1.8	3.3	V	--
Normal Mode Current Consumption	IDD	--	9	--	mA	--
Level Input Voltage	V _{IH}	0.7*IOVCC	--	IOVCC	V	--
	V _{IL}	GND	--	0.3*IOVCC	V	--
Level Output Voltage	V _{OH}	0.8*IOVCC	--	IOVCC	V	--
	V _{OL}	GND	--	0.2*IOVCC	V	--

5.3 LED Backlight Characteristics

The backlight system is edge lighting type with 8 LED Chips

Item	Symbol	Min	Typ.	Max	Unit	Note
Forward Current	I_F	120	160	--	mA	--
Forward Voltage	V_F	--	3.2	--	V	--
LCM Luminance	L_v	400	450	--	cd/m ²	(3)
LED Lifetime	H_r	50000	--	--	hour	(1)(2)
Uniformity	Avg	80	--	--	%	(3)

Note 1: LED lifetime (H_r) can be defined as the time in which it continues to operate under the condition: $T_a=25 \pm 3^\circ\text{C}$, typical IL value indicated in the above table until the brightness becomes less than 50%.

Note 2: The "LED lifetime" is defined as the module brightness decrease to 50% original brightness at $T_a=25^\circ\text{C}$ and $I_F = 160\text{mA}$. The LED lifetime could be decreased if operating I_F is larger than 160mA. The constant current driving method is suggested.

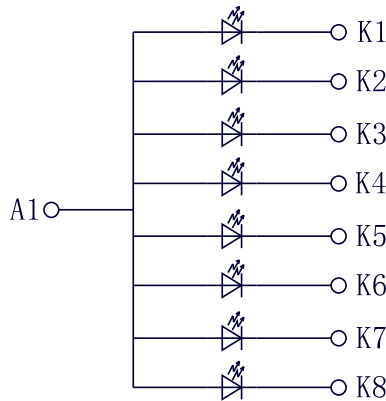

BL CIRCUIT DIAGRAM

Note 3: Luminance Uniformity of these 9 points is defined as below:

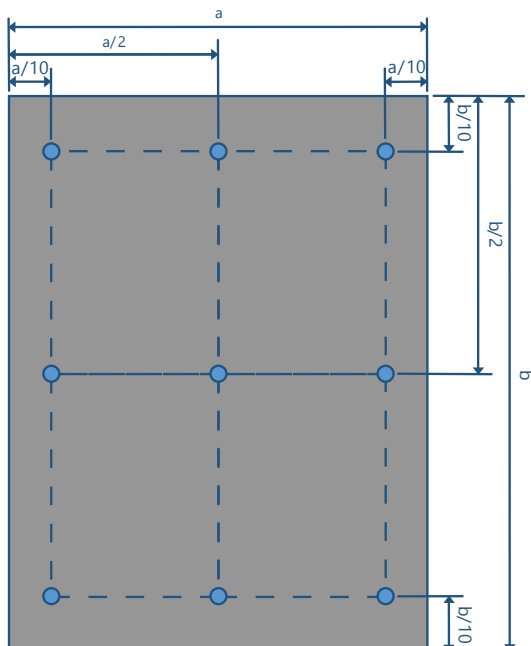

$$\text{Luminance} = \frac{\text{Total Luminance of 9 Points}}{9}$$

$$\text{Uniformity} = \frac{\text{Minimum Luminance in 9 Points (1-9)}}{\text{Maximum Luminance in 9 Points (1-9)}}$$

6. TFT AC Characteristics

6.1 Parallel Interface Characteristics (8080-series MPU)

For 8080 Series MCU parallel interface timing characteristics, diagrams and tables, see table and diagrams on page 120 of the data sheet for controller HX8347A. The data sheet can be found here:

<https://focuslcds.com/wp-content/uploads/Drivers/HX8347.pdf>

6.2 Parallel Interface Characteristics (6800-series MPU)

For 6800 Series MCU parallel interface timing characteristics, diagrams and tables, see table and diagrams on page 122 of the data sheet for controller HX8347A. The data sheet can be found here:

<https://focuslcds.com/wp-content/uploads/Drivers/HX8347.pdf>

6.3 Serial Interface Characteristics

For serial interface timing characteristics (3-line serial), diagrams and tables, see table and diagram page 123 of the data sheet for controller HX8347A. The data sheet can be found here:

<https://focuslcds.com/wp-content/uploads/Drivers/HX8347.pdf>

6.4 RGB Interface Characteristics

For parallel RGB interface timing characteristics tables and diagram, see page 124 of the data sheet for controller HX8347A. The data sheet can be found here: <https://focuslcds.com/wp-content/uploads/Drivers/HX8347.pdf>

6.5 Reset Timing Characteristics

For the reset timing characteristics table and diagram, see page 125 for the data sheet for controller HX8347A. The data sheet can be found here: <https://focuslcds.com/wp-content/uploads/Drivers/HX8347.pdf>

7. Quality Inspection Standards

For TFT quality inspection standards, please see the following link: <https://focuslcds.com/lcd-resources/tft-quality-inspection-standards/>

8. Cautions and Handling Precautions

8.1 Handling and Operating the Module

1. When the module is assembled, it should be attached to the system firmly. Do not warp or twist the module during assembly work.
2. Protect the module from physical shock or any force. In addition to damage, this may cause improper operation or damage to the module and back-light unit.
3. Note that polarizer is very fragile and could be easily damaged. Do not press or scratch the surface.
4. Do not allow drops of water or chemicals to remain on the display surface. If you have the droplets for a long time, staining and discoloration may occur.
5. If the surface of the polarizer is dirty, clean it using some absorbent cotton or soft cloth.
6. The desirable cleaners are water, IPA (Isopropyl Alcohol) or Hexane. Do not use ketene type materials (ex. Acetone), Ethyl alcohol, Toluene, Ethyl acid or Methyl chloride. It might permanent damage to the polarizer due to chemical reaction.
7. If the liquid crystal material leaks from the panel, it should be kept away from the eyes or mouth. In case of contact with hands, legs, or clothes, it must be washed away thoroughly with soap.
8. Protect the module from static; it may cause damage to the CMOS ICs.
9. Use fingerstalls with soft gloves in order to keep display clean during the incoming inspection and assembly process.
10. Do not disassemble the module.
11. Protection film for polarizer on the module shall be slowly peeled off just before use so that the electrostatic charge can be minimized.
12. Pins of I/F connector shall not be touched directly with bare hands.
13. Do not connect, disconnect the module in the "Power ON" condition.
14. Power supply should always be turned on/off by the item Power On Sequence & Power Off Sequence.

8.2 Storage and Transportation

1. Do not leave the panel in high temperature, and high humidity for a long time. It is highly recommended to store the module with temperature from 0 to 35 °C and relative humidity of less than 70%.
2. Do not store the TFT-LCD module in direct sunlight.
3. The module shall be stored in a dark place. When storing the modules for a long time, be sure to adopt effective measures for protecting the modules from strong ultraviolet radiation, sunlight, or fluorescent light.
4. It is recommended that the modules should be stored under a condition where no condensation is allowed. Formation of dewdrops may cause an abnormal operation or a failure of the module. In particular, the greatest possible care should be taken to prevent any module from being operated where condensation has occurred inside.
5. This panel has its circuitry FPC on the bottom side and should be handled carefully in order not to be stressed.