



FocusLCDs.com
LCDs MADE SIMPLE®

Ph. 480-503-4295 | NOPP@FocusLCD.com

TFT | CHARACTER | UWVD | FSC | SEGMENT | CUSTOM | REPLACEMENT

TFT Display Module

Part Number

E43RC-HS459-C

Overview:

- 4.3-inch TFT: 105.4x67.15mm
- 800x480 pixels
- HDMI Interface
- Micro-USB CTP Interface
- White LED back-light
- Transmissive
- Capacitive Touch Panel
- 459 NITS
- Controller: HX8264-E+HX8664-B
- RoHS Compliant

Description

This is a color active matrix TFT (Thin Film Transistor) LCD (Liquid Crystal Display) that uses amorphous silicon TFT as a switching device. This model is composed of a transmissive type TFT-LCD Panel, driver circuit, capacitive touch panel and a backlight unit. The resolution of the 4.3" TFT-LCD contains 800(RGB)x480 pixels.

TFT Features

Low Input Voltage: 3.3V

TFT Interface: HDMI

CTP Interface: Micro-USB

General Information Items	Specification	Unit	Note
	Main Panel		
TFT Display area (AA)	95.04 (H) x 53.86 (V) (4.3 inch)	mm	-
Driver element	TFT active matrix	-	-
Display Colors	65k/262k/16.7M	colors	-
Number of pixels	800(RGB)x480	dots	-
TFT Pixel arrangement	RGB vertical stripe	-	-
Pixel pitch	0.1188 (H) x 0.1122 (V)	mm	-
Viewing angle	ALL	o'clock	-
TFT Controller IC	HX8264-E+HX8664-B	-	-
LCM+CTP Luminance	459 nits (TYP)	-	-
CTP Interface	Micro-USB	-	-
Touch Cover Thickness	0.7mm with chemical strengthening	-	-
Touch Point	Five points and Gestures	-	-
Video Input	HDMI	-	-
Operating temperature	-30~+85	°C	-
Storage temperature	-30~+85	°C	-

Mechanical Information

Item		Min	Typ.	Max	Unit	Note
Module size	Height (H)		105.40		mm	-
	Vertical (V)		67.15		mm	-
	Depth (D)		4.36		mm	-

1. Outline Dimensions

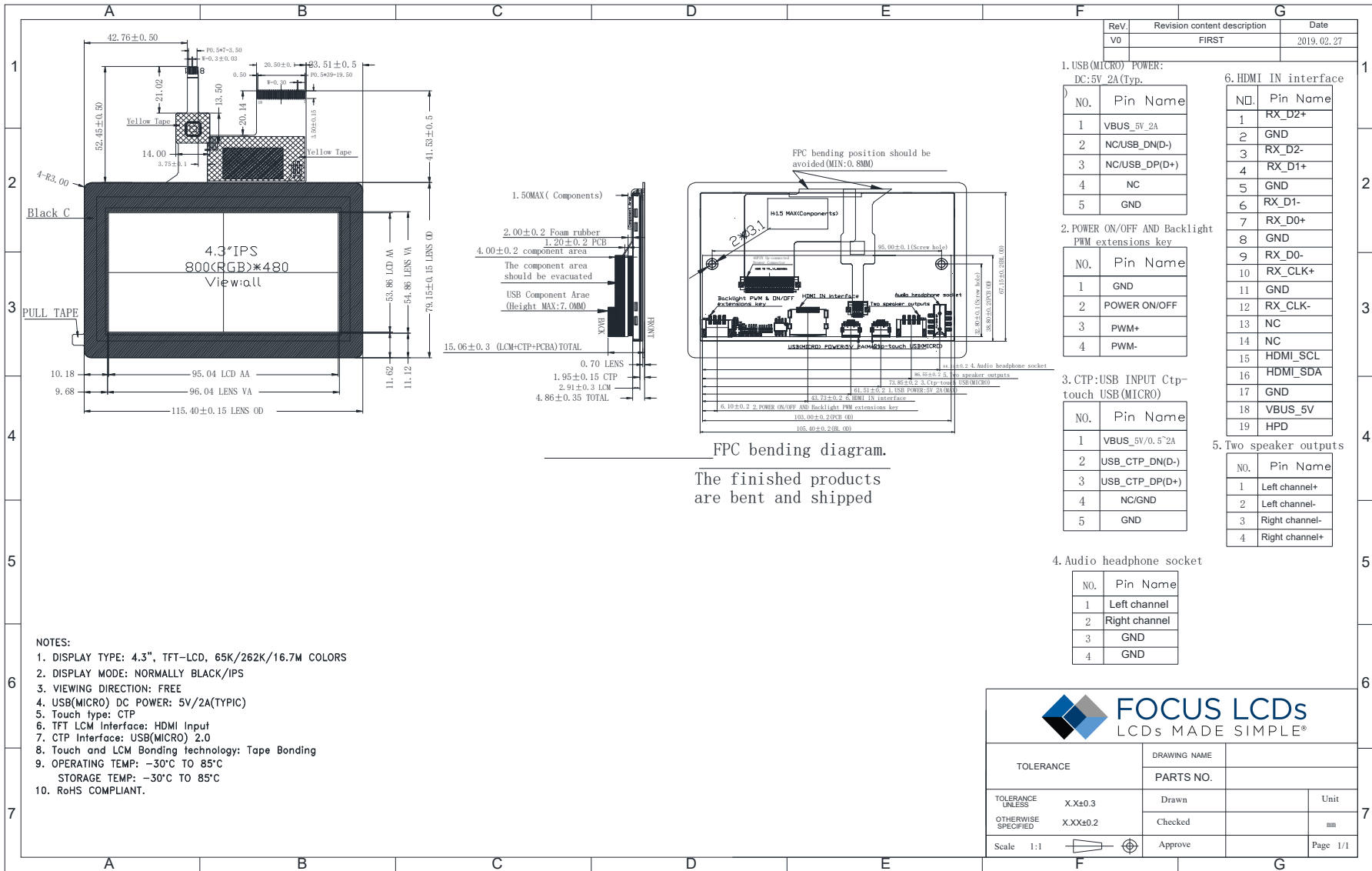

2. Block Diagram



3. Input Terminal Pin Assignment

3.1 Micro USB Pin Definition & Signal Connector

NO.	Symbol	Description	I/O
1	DC:5V, 2A (Typ.)	Supply voltage (5V, 2A Typ.)	P
2	NC	No connection	--
3	NC	No connection	--
4	NC	No connection	--
5	GND	Ground	P

I: Input, O: Output, P: Power

Micro-USB Connector Dimensions:

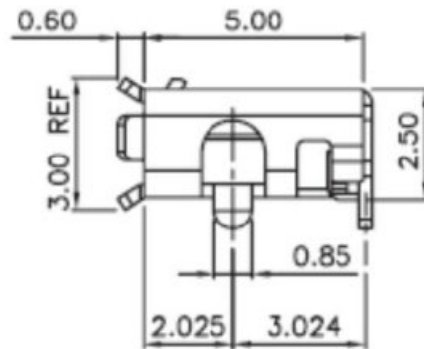
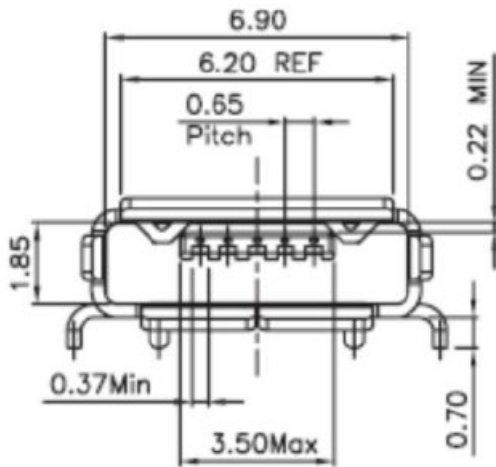
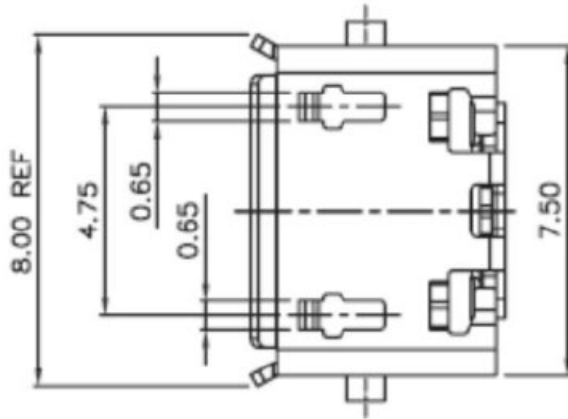

3.2 Power ON/OFF and Backlight PWM Extension Key Pin Definition & Signal Connector

NO.	Symbol	Description	I/O
1	GND	Ground	P
2	Power ON/OFF	ON/OFF key	P
3	PWM+	The backlight brightness of each button is increased by one level until the maximum brightness reaches level 9	I
4	PWM-	The backlight brightness of each button is reduced by one level until the lowest brightness reaches level 9	I

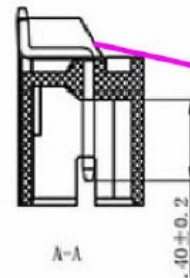
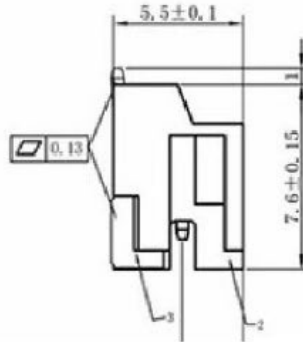
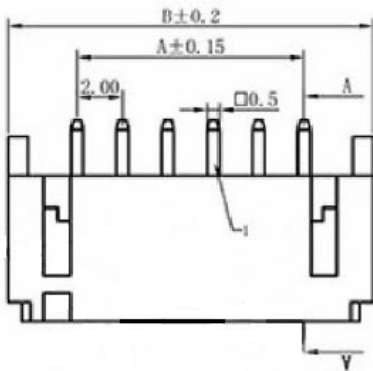
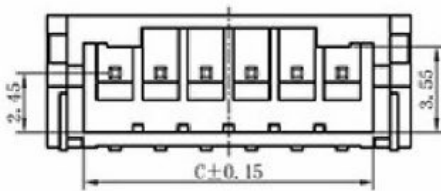
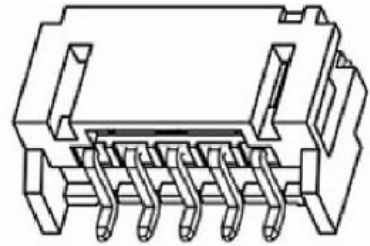

poles	A	B	C
2	2.00	8.00	4.75
3	4.00	10.00	6.75
4	6.00	12.00	8.75
5	8.00	14.00	10.75
6	10.00	16.00	12.75
7	12.00	18.00	14.75
8	14.00	20.00	16.75
9	16.00	22.00	18.75

3.3 CTP: Micro USB Pin Definition & Signal Connector

NO.	Symbol	Description	I/O
1	DC:5V,2A(Typ.)	Supply voltage (5V, 2A Typ.)	P
2	USB_CTP_DN(D-)	USB data negative analog input	I/O
3	USB_CTP_DP(D+)	USB data positive analog input	I/O
4	NC	No connection	I
5	GND	Ground	P

Micro USB Connector Dimensions:

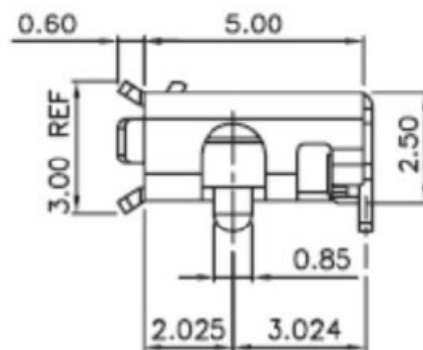
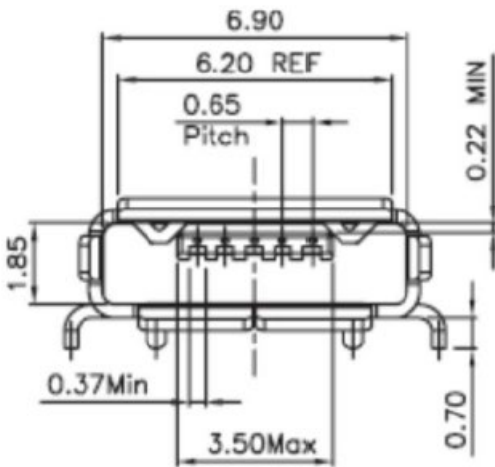
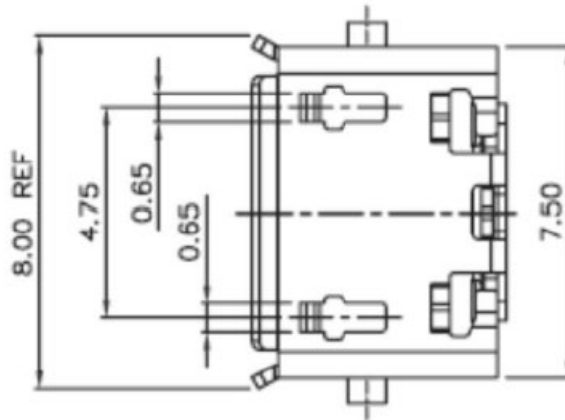

3.4 Audio Headphone Socket Pin Definition & Input Signal Connector

NO.	Symbol	Description	I/O
1	Left channel	Audio output left channel	
2	Right channel	Audio output right channel	
3	GND	Ground	
4	GND	Ground	

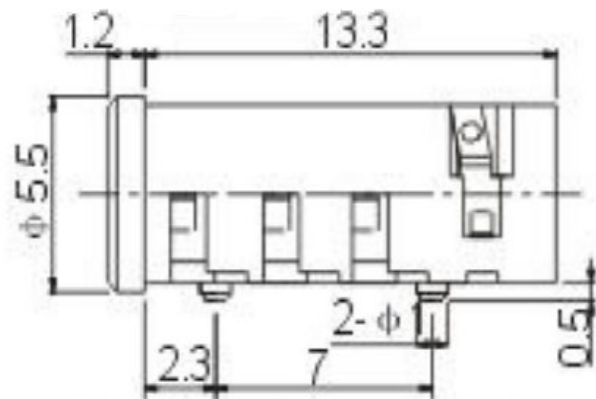
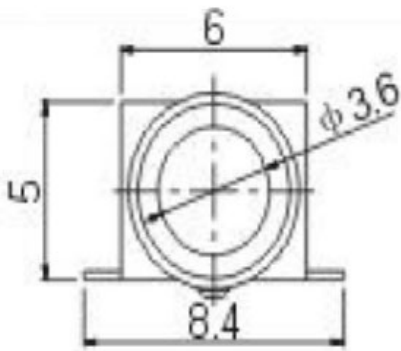

P.C.B Layout(copper-sided view)

3.5 Two Speaker Outputs Pin Definition & Input Signal Connector

NO.	Symbol	Description	I/O
1	Left channel+	Audio output left channel	
2	Left channel-		
3	Right channel-	Audio output right channel	
4	Right channel+		

Note: SMT PH2.0mm spacing connector 4p

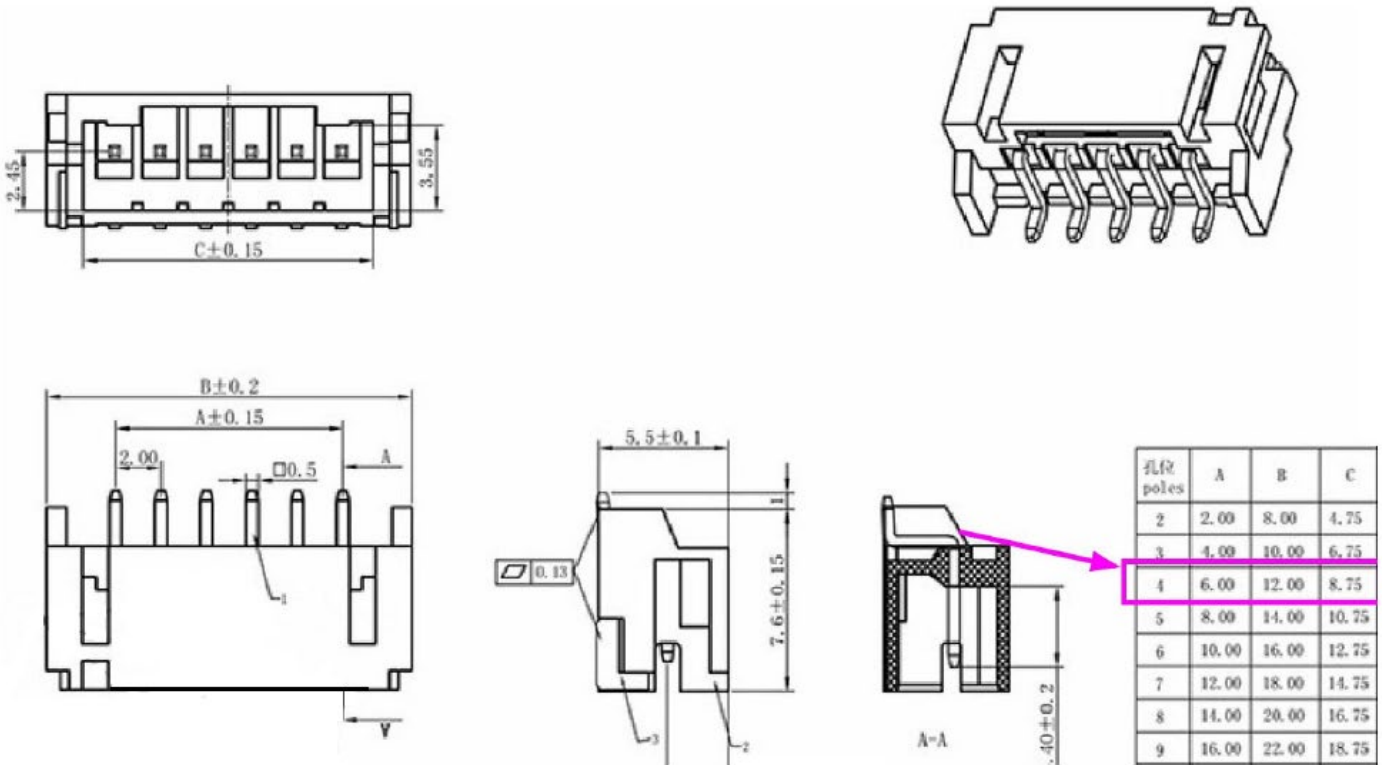

3.6 HDMI Pin Definition & Signal Connector

NO.	Symbol	Description	I/O
1	RX_D2+	HDMI receiver channel 2 positive analog input	I
2	GND	Ground	P
3	RX_D2-	HDMI receiver channel 2 negative analog input	I
4	RX_D1+	HDMI receiver channel 1 positive analog input	I
5	GND	Ground	P
6	RX_D1-	HDMI receiver channel 1 negative analog input	I
7	RX_D0+	HDMI receiver channel 0 positive analog input	I
8	GND	Ground	P
9	RX_D0-	HDMI receiver channel 0 negative analog input	I
10	RX_CLK+	HDMI receiver clock positive analog input	I
11	GND	Ground	P
12	RX_CLK-	HDMI receiver clock negative analog input	I
13	NC	Not connected	
14	NC	Not connected	
15	HDMI_SCL	HDMI receiver DDC data channel	I/O
16	HDMI_SDA	HDMI receiver DDC clock channel	I
17	GND	Ground	P
18	HDMI_5V	HDMI supply voltage (5V)	P
19	HPD	HDMI receiver hot plug detect output	O

HDMI Connector Dimensions:

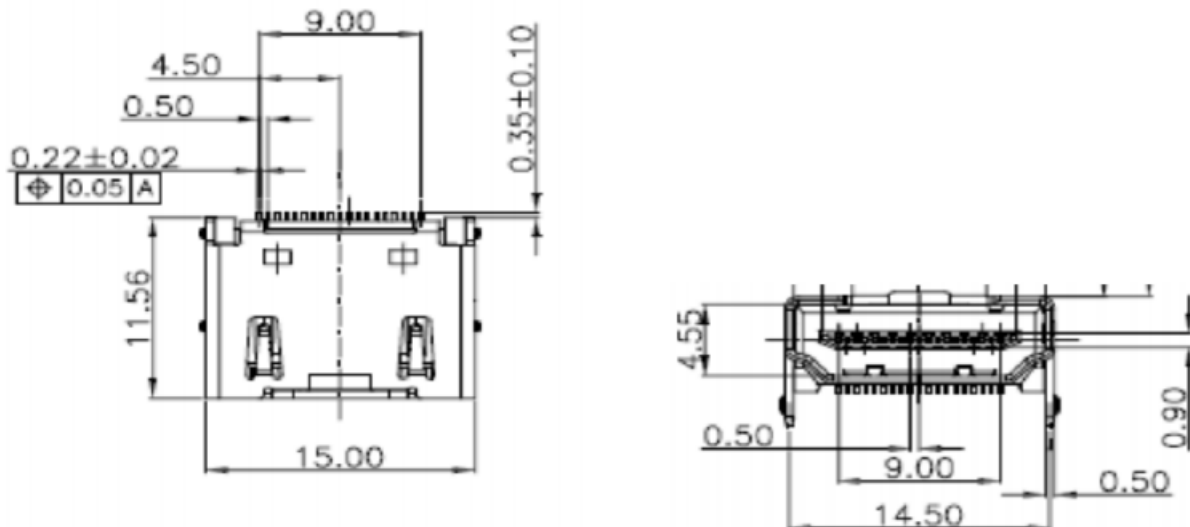

4. LCD Optical Characteristics

4.1 Optical Specifications

Item	Symbol	Condition	Min	Typ.	Max	Unit	Note	
Contrast Ratio	CR	Normal Viewing Angle $\theta=0$	640	800	--	--	(2)	
Response Time	Rising		TR + TF	--	30	40	ms	(4)
	Falling							
Color Filter Chromaticity	White		W _X	0.293	0.333	0.373	--	(5)(6)
			W _Y	0.330	0.370	0.410		
	Red		R _X	0.564	0.604	0.644		
			R _Y	0.314	0.354	0.394		
	Green		G _X	0.324	0.364	0.404		
			G _Y	0.550	0.589	0.629		
	Blue		B _X	0.110	0.151	0.191		
		B _Y	0.063	0.104	0.144			
Viewing Angle	Hor.	Θ_L	--	80	--	degree	(1)(6)	
		Θ_R	--	80	--			
	Ver.	Θ_T	--	80	--			
		Θ_B	--	80	--			
Option View Direction	FREE						(1)	

4.2 Operating Instructions

This product supports the following operating systems: Windows 7/8/10, Raspberry Pi, Ubuntu and Android.

Connect the HDMI cable to Windows 7/8/10, Raspberry Pi, Ubuntu or Android.

Connect the CTP to micro USB.

Connect the micro USB to DC power.

4.3 Test Conditions

VDD=3.3V, IL=300mA (Backlight current), the ambient temperature is 25°C

Optical Specification Reference Notes:

(1) Definition of Viewing Angle: The viewing angle is the angle at which the contrast ratio is greater than 10. The viewing angles are determined for the horizontal or 3,9 o'clock direction and the vertical or 6,12 o'clock direction with respect to the optical axis which is normal to the LCD surface.

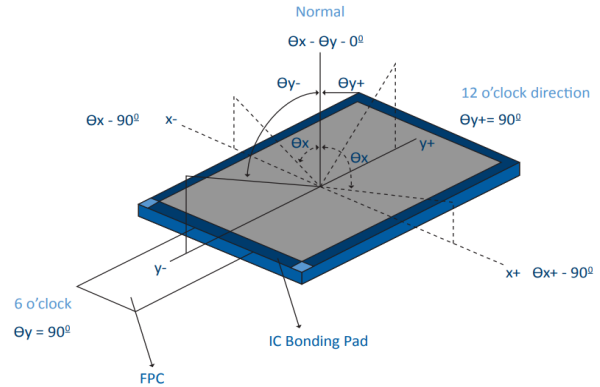
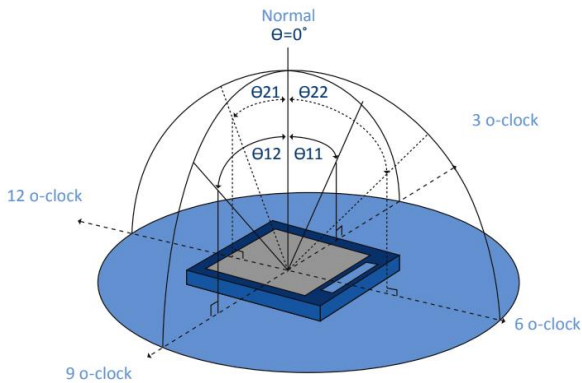

(2) Definition of Contrast Ratio (Cr): measured at the center point of panel. The contrast ratio (Cr) measured on a module, is the ratio between the luminance (Lw) in a full white area (R=G=B=1) and the luminance (Ld) in a dark area (R=G=B=0).

$$Cr = \frac{Lw}{Ld}$$

(3) Definition of transmittance (T%): The transmittance of the panel including the polarizers is measured with electrical driving. The equation for transmittance Tr is:

$$Tr = \frac{It}{Io} \times 100\%$$

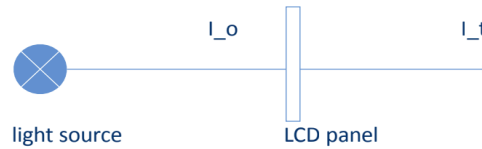

Io = the brightness of the light source.
It = the brightness after panel transmission

(4) Definition of Response Time (Tr, Tf): The rise time 'Tr' is defined as the time for luminance to change from 90% to 10% as a result of a change of the electrical condition. The fall time 'Tf' is defined as the time for luminance to change from 10% to 90% as a result of a change of the electrical condition.

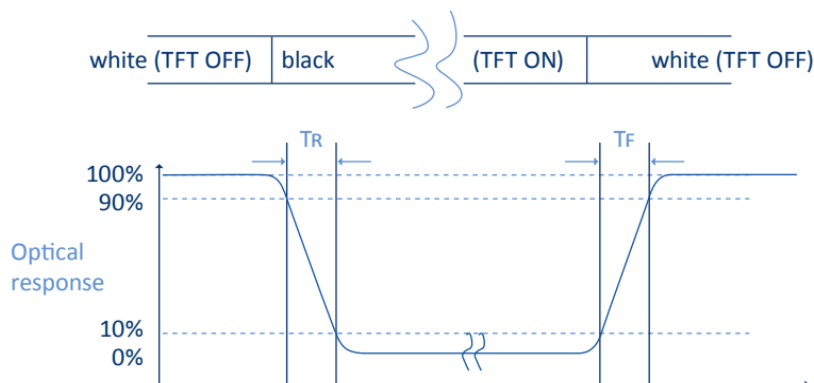

(5) Definition of Color Gamut:

Measuring machine CFT-01. NTSC's Primaries: R(x,y,Y), G(x,y,Y), B(x,y,Y). FPM520 of Westar Display Technologies, INC., which utilized SR-3 for Chromaticity and BM-5A for other optical characteristics. The color chromaticity shall be calculated from the spectral data measured with all pixels first in red, green, blue and white. Measurements shall be made at the center of the panel.

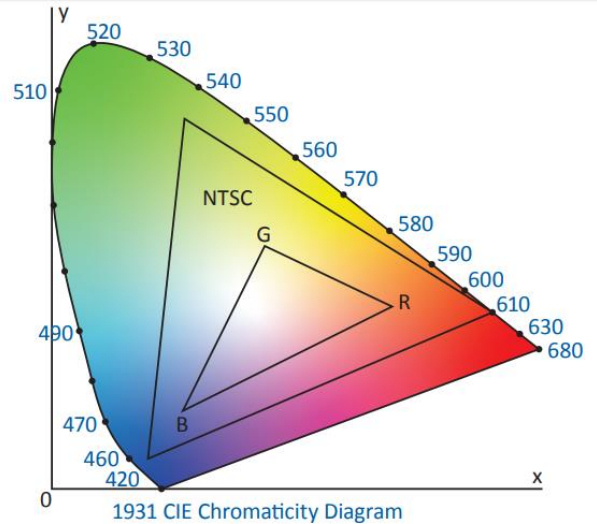
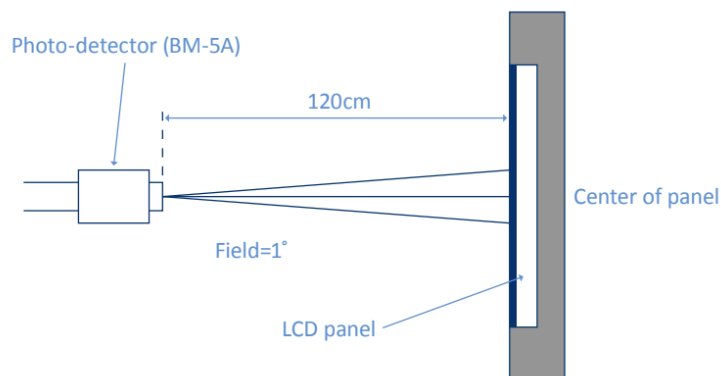
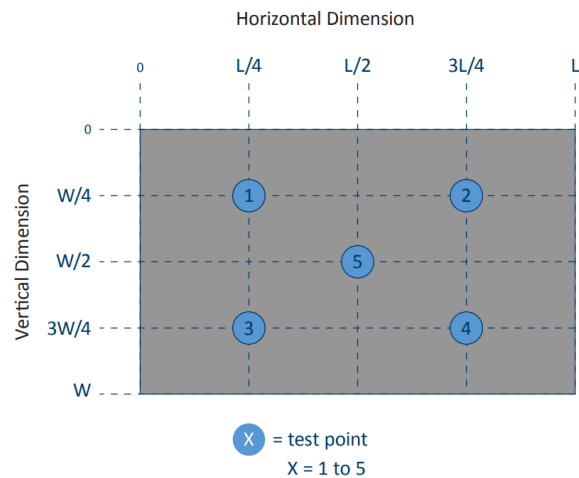
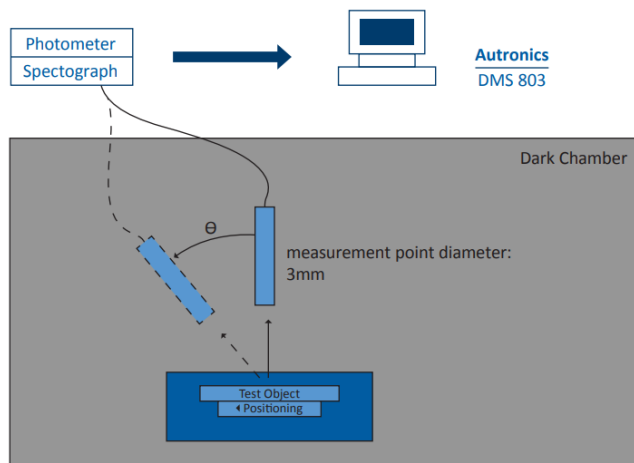

Fig. 1931 CIE chromacity diagram

$$\text{Color gamut: } S = \frac{\text{Area of RGB triangle}}{\text{Area of NTSC triangle}} \times 100\%$$

(6) Definition of Optical Measurement Setup:

The LCD module should be stabilized at a given temperature for 20 minutes to avoid abrupt temperature change during measuring. In order to stabilize the luminance, the measurement should be executed after lighting backlight for 20 minutes.



5. Electrical Characteristics

5.1 Absolute Maximum Rating (Ta=25 °C, VSS=0V)

Characteristics	Symbol	Min	Max	Unit	Note
Power Supply Voltage (Analog)	VDD-GND	-0.3	6.0	V	
	VDDp-GND	-0.3	6.0	V	
Input Signal Voltage (LED)	VLED	-0.3	6.0	V	LED_EN
Input Signal Voltage (PWR)	VPWR	-0.3	5.5	V	DCDC_EN
Operating Temperature	TOP	-30	+70	°C	
Storage Temperature	TST	-30	+80	°C	

NOTE: If the absolute maximum rating of the above parameters is exceeded, even momentarily, the quality of the product may be degraded. Absolute maximum ratings specify the values which the product may be physically damaged if exceeded. Be sure to use the product within the range of the absolute maximum ratings.

5.2 DC Electrical Characteristics

Characteristics	Symbol	Min.	Typ.	Max.	Unit	Note
Digital Supply Voltage	VDD	2.7	3.3	3.6	V	
Interface Operation Voltage	IOVCC	--	--	--	V	
Normal Mode Current Consumption	IDD	--	120	--	mA	
Level input voltage	VIH	0.7 VDD		VDD	V	
	VIL	GND		0.3 VDD	V	
Level output voltage	VOH	VDD-0.4		--	V	
	VOL	GND		GND+0.4	V	

5.3 LED Backlight Characteristics

Item	Symbol	Min	Typ.	Max	Unit	Note
Forward Current	IF	30	40	--	mA	
Forward Voltage	VF	--	16	--	V	
LCM Luminance	LV	409	459	--	cd/m ²	Note 3
LED lifetime	Hr	--	50000	--	hour	Note1 & 2
Uniformity	AVg	80	--	--	%	Note 3

The back-light system is edge-lighting type with 10 chips LED

Note 1: LED lifetime (Hr) can be defined as the time in which it continues to operate under the condition: Ta=25 ±3 °C, typical IL value indicated in the above table until the brightness becomes less than 50%.

Note 2: The “LED lifetime” is defined as the module brightness decrease to 50% original brightness at Ta=25°C and IL=40mA. The LED lifetime could be decreased if operating IL is larger than 40mA. The constant current driving method is suggested.

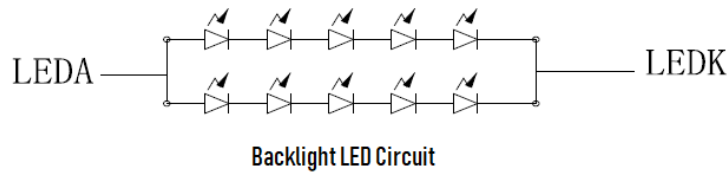

Note 3: Luminance Uniformity of these 9 points is defined as below:

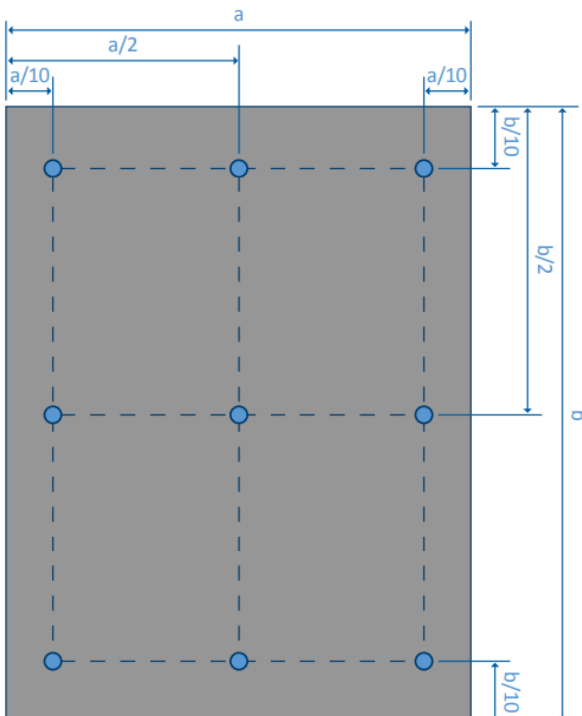

$$\text{Luminance} = \frac{\text{(Total Luminance of 9 points)}}{9}$$

$$\text{Uniformity} = \frac{\text{minimum luminance in 9 points(1-9)}}{\text{maximum luminance in 9 points(1-9)}}$$

6. AC Characteristics

6.1 AC Electrical Characteristics

Parameter	Symbol	Min	Typ.	Max	Unit	Note
HS Setup Time	Thst	8	--	--	ns	
HS Hold Time	Thhd	8	--	--	ns	
VS Setup Time	Tvst	8	--	--	ns	
VS Hold Time	Tvhd	8	--	--	ns	
Data Setup Time	Tdsu	8	--	--	ns	
Data Hold Time	Tdhd	8	--	--	ns	
DE Setup Time	Tesu	8	--	--	ns	
DE Hold Time	Tehd	8	--	--	ns	
DVDD Power On Slew Rate	TPOR	--	--	20	ms	From 0 to 90% DVDD
Reset Pulse Width	TRst	10	--	--	ns	
DCLK Cycle Time	Tcoh	20	--	--	ns	
DCLK Pulse Duty	Tcwh	40	50	60	%	

Table 6.1: AC Electrical Timing Characteristics

6.2 Horizontal and Vertical Data Timing

Parameter	Symbol	Min	Typ.	Max	Unit	Note
Horizontal Display Area	thd	--	800	--	DCLK	
DCLK Frequency	fclk	--	30	50	MHz	
One Horizontal Line	th	862	1056	1200	DCLK	
HS Pulse Width	thpw	1	--	40	DCLK	
HS Blanking	thb	46	46	46	DCLK	
HS Front Porch	thfp	16	210	354	DCLK	

Table 6.2: Horizontal Data Timing Characteristics

Parameter	Symbol	Min	Typ.	Max	Unit	Note
Vertical Display Area	tvd	--	480	--	TH	
VS Period Time	tv	513	525	650	TH	
VS Pulse Width	tvpw	3	--	20	TH	
VS Blanking	tvb	23	23	23	TH	
VS Front Porch	tvfp	7	22	147	TH	

Table 6.3: Vertical Data Timing Characteristics

6.3 Timing Diagrams

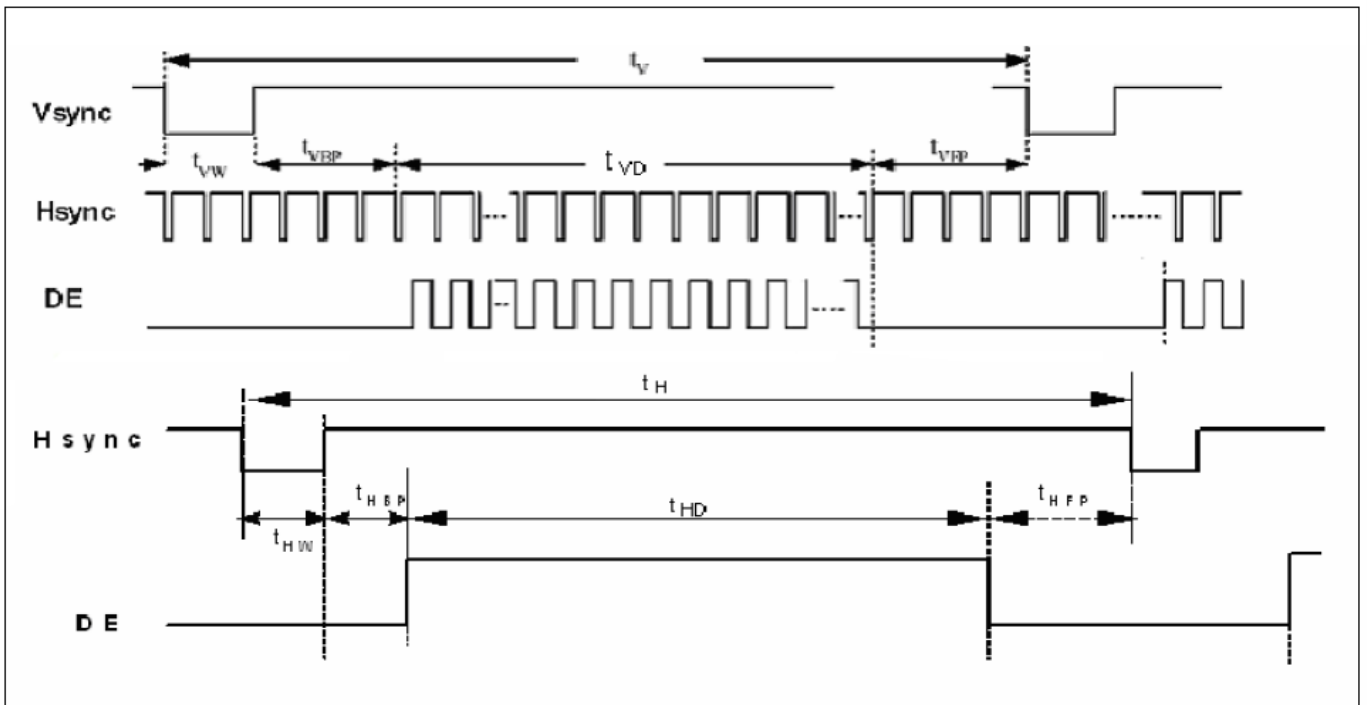

6.3 Timing Diagrams

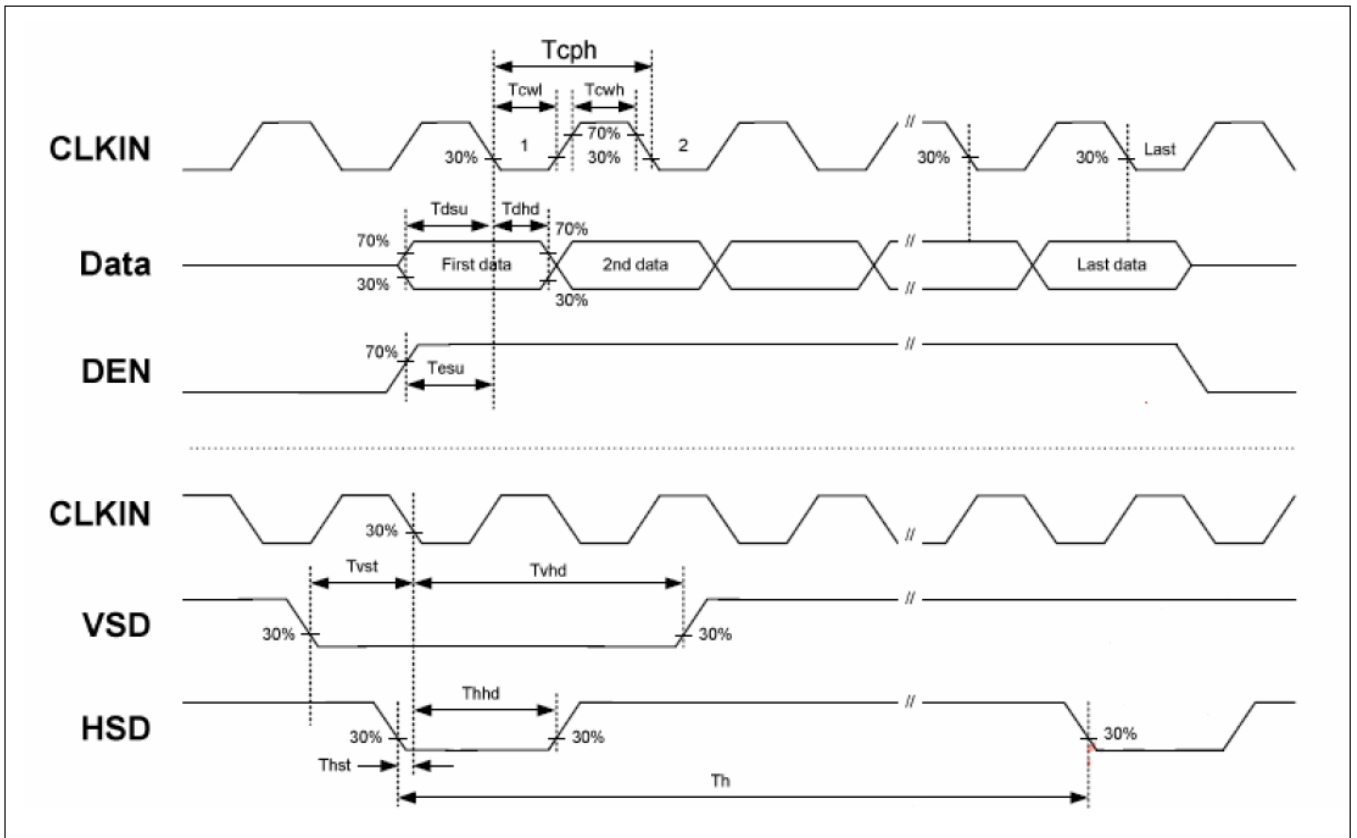

Figure 6.1: Clock and Data Timing Diagram

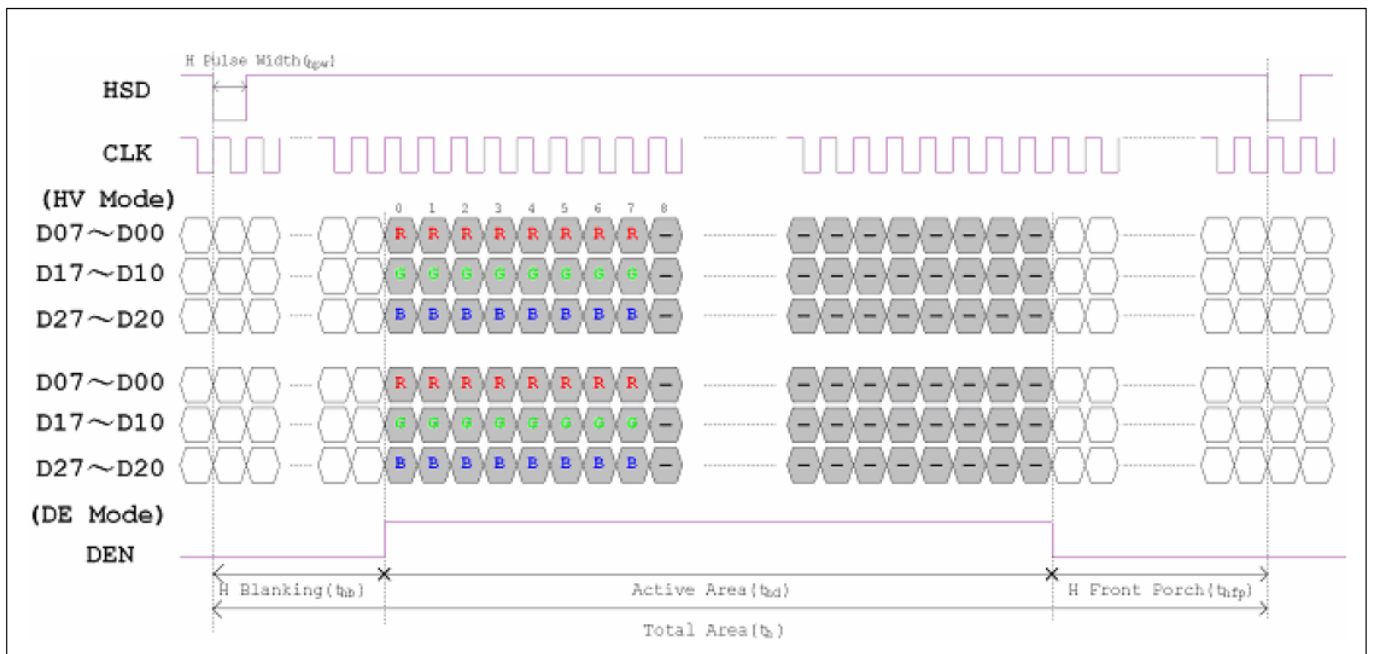

Figure 6.2: HV and DE Clock and Data Timing Diagram

7. CTP Electrical Characteristics

7.1 Absolute Maximum Rating

Item	Symbol	Min	Max	Unit	Note
Power Supply Voltage	VDD	2.7	3.6	V	1
I/O Digital Voltage	VDDIO	--	--	V	1
Operating Temperature	T _{OP}	-30	+85	°C	-
Storage Temperature	T _{ST}	-30	+85	°C	-

Note: If used beyond the absolute maximum ratings, FT5436 may permanently damage. It is strongly recommended that the device be used within the electrical characteristics in normal operations. If exposed to the condition not within the electrical characteristics, it may affect the reliability of the device.

7.2 DC Electrical Characteristics (Ta=25°C)

Item	Symbol	Condition	Min	Typ.	Max	Unit	Note
Digital supply voltage	VDD		2.7	3.3	3.47	V	
I/O Digital supply voltage	VDDIO		--	--	--	V	
Normal operation mode current consumption	I _{OPr}	VDD=2.7V Ta=25°C MCLK=17.5M Hz		11		mA	
Monitor mode current consumption	I _{mon}			0.43		mA	
Sleep mode current consumption	I _{slp}			42		uA	
Level input voltage	V _{IH}		0.7VDD		VDD	V	
	V _{IL}		-0.3		0.3VDD	V	
Level output voltage	V _{OH}	I _{OH} =-0.1mA	0.7VDD			V	
	V _{OL}	I _{OL} =0.1mA			0.3VDD	V	

7.3 AC Characteristics

Item	Symbol	Test Condition	Min	Typ.	Max	Unit	Note
OSC clock 1	fosc1	VDDA=2.7V; Ta=25°C	49	50	51	MHz	
Sensor acceptable clock	ftx	VDDA=2.8V; Ta=25°C	0	100	300	kHz	
Sensor output rise time	T _{txr}	VDDA=2.8V; Ta=25°C	-	100	-	Ns	
Sensor output fall time	T _{txf}	VDDA=2.8V; Ta=25°C	-	80	-	Ns	
Sensor input voltage	Trxi	VDDA=2.8V; Ta=25°C	-	5	-	V	

7.4 I2C Interface

The I2C is always configured in the slave mode. The data transfer format is shown below.

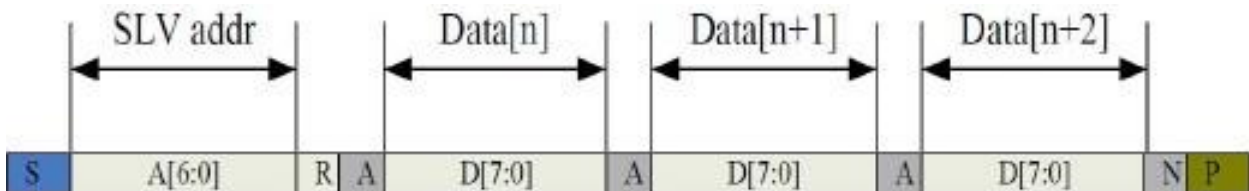
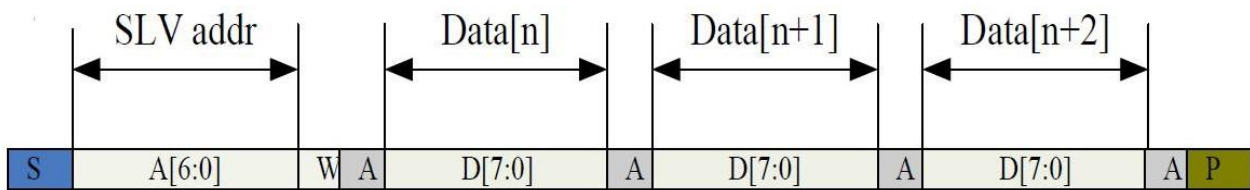
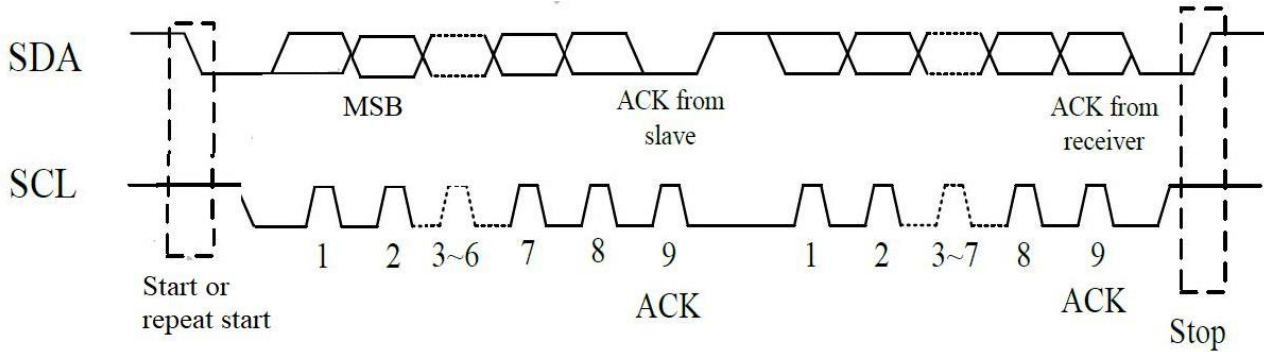

The following table lists the meanings of the mnemonics used in the above figures.

Mnemonics	Description
S	I2C start or I2C restart
A [6:0]	Slave address
R/W	Read/Write bit, '1' for read, '0' for write
A(N)	ACK(NACK)
P	Stop: the indication of the end of a packet (if this bit is missing, S will indicate the end of the current packet and the beginning of the next packet)

I2C Interface Timing Characteristics

Parameter	Min	Max	Unit
SCL frequency	0	400	kHz
Bus free time between a stop and start condition	1.3	-	us
Hold time (repeated) start condition	0.6	-	us
Data setup time	100	-	us
Setup time for a repeated start condition	0.6	-	us
Setup time for stop condition	0.6	-	us

7.5 Power ON/Reset Sequence

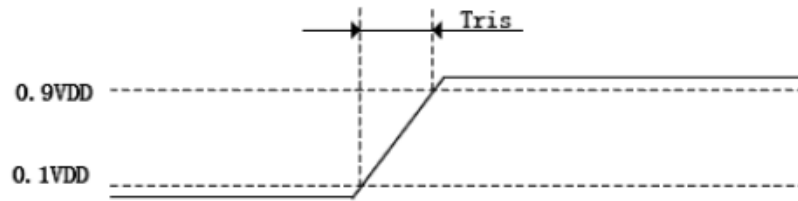

Power On Time

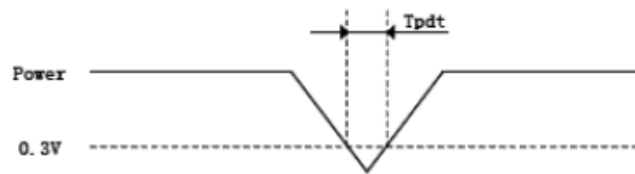

Power Cycle Requirement



Power on Sequence

Parameter	Description	Min	Max	Units
Tris	Rise time from 0.1VDD to 0.9VDD	--	5	ms
Tpdt	Time of voltage being below 0.3V	5	--	ms
Trtp	Time of resetting low before powering on	100	--	us
Tvdr	Reset time	1	--	ms
Trsi	Time of starting to report point after resetting	--	200	ms

8. Cautions and Handling Precautions

8.1 Handling and Operating the Module

1. When the module is assembled, it should be attached to the system firmly. Do not warp or twist the module during assembly work.
2. Protect the module from physical shock or any force. In addition to damage, this may cause improper operation or damage to the module and back-light unit.
3. Note that polarizer is very fragile and could be easily damaged. Do not press or scratch the surface.
4. Do not allow drops of water or chemicals to remain on the display surface. If you have the droplets for a long time, staining and discoloration may occur.
5. If the surface of the polarizer is dirty, clean it using some absorbent cotton or soft cloth.
6. The desirable cleaners are water, IPA (Isopropyl Alcohol) or Hexane. Do not use ketene type materials (ex. Acetone), Ethyl alcohol, Toluene, Ethyl acid or Methyl chloride. It might permanent damage to the polarizer due to chemical reaction.
7. If the liquid crystal material leaks from the panel, it should be kept away from the eyes or mouth. In case of contact with hands, legs, or clothes, it must be washed away thoroughly with soap.
8. Protect the module from static; it may cause damage to the CMOS ICs.
9. Use fingerstalls with soft gloves in order to keep display clean during the incoming inspection and assembly process.
10. Do not disassemble the module.
11. Protection film for polarizer on the module shall be slowly peeled off just before use so that the electrostatic charge can be minimized.
12. Pins of I/F connector shall not be touched directly with bare hands.
13. Do not connect, disconnect the module in the "Power ON" condition.
14. Power supply should always be turned on/off by the item Power On Sequence & Power Off Sequence.

8.2 Storage and Transportation

1. Do not leave the panel in high temperature, and high humidity for a long time. It is highly recommended to store the module with temperature from 0 to 35 °C and relative humidity of less than 70%
2. Do not store the TFT-LCD module in direct sunlight.
3. The module shall be stored in a dark place. When storing the modules for a long time, be sure to adopt effective measures for protecting the modules from strong ultraviolet radiation, sunlight, or fluorescent light.
4. It is recommended that the modules should be stored under a condition where no condensation is allowed. Formation of dewdrops may cause an abnormal operation or a failure of the module. In particular, the greatest possible care should be taken to prevent any module from being operated where condensation has occurred inside.
5. This panel has its circuitry FPC on the bottom side and should be handled carefully in order not to be stressed.