



FocusLCDs.com  
LCDs MADE SIMPLE®

Ph. 480-503-4295 | [NOPP@FocusLCD.com](mailto:NOPP@FocusLCD.com)

TFT | CHARACTER | UWVD | FSC | SEGMENT | CUSTOM | REPLACEMENT

## Graphic Display Module

### Part Number

G126BYGFFWSW6WT

### Overview

COG, 128x64(71.3x54.9), FSTN, White background, Edge lit, White LED backlight, Bottom view, Wide temp, Transflective (positive) IC: SPLC501C, RoHS Compliant

## 1. Features

1. 128\*65 dots
2. 68 MPU interfaces
3. Built-in controller (SPLC501C)
4. Display Mode & Backlight Variations
5. ROHS Compliant

<b>LCD type</b>	<input type="checkbox"/> TN			
	<input checked="" type="checkbox"/> FSTN	<input type="checkbox"/> FSTN Negative		
	<input type="checkbox"/> STN Yellow Green	<input type="checkbox"/> STN Gray	<input type="checkbox"/> STN Blue Negative	
<b>View direction</b>	<input checked="" type="checkbox"/> 6 O'clock		<input type="checkbox"/> 12 O'clock	
<b>Rear Polarizer</b>	<input type="checkbox"/> Reflective		<input checked="" type="checkbox"/> Transflective	<input type="checkbox"/> Transmissive
<b>Backlight Type</b>	<input checked="" type="checkbox"/> LED Edge	<input type="checkbox"/> EL	<input type="checkbox"/> Internal Power	<input checked="" type="checkbox"/> 3.0V Input
	<input type="checkbox"/> LED Array	<input type="checkbox"/> CCFL	<input checked="" type="checkbox"/> External Power	<input type="checkbox"/> 5.0V Input
<b>Backlight Color</b>	<input checked="" type="checkbox"/> White	<input type="checkbox"/> Blue	<input type="checkbox"/> Amber	<input type="checkbox"/> Yellow-Green
<b>Temperature Range</b>	<input type="checkbox"/> Normal		<input checked="" type="checkbox"/> Wide	<input type="checkbox"/> Super Wide
<b>DC to DC circuit</b>	<input checked="" type="checkbox"/> Build-in			<input type="checkbox"/> Not Build-in
<b>Touch screen</b>	<input type="checkbox"/> With			<input checked="" type="checkbox"/> Without
<b>Font type</b>	<input type="checkbox"/> English-Japanese	<input type="checkbox"/> English-European	<input type="checkbox"/> English-Russian	<input checked="" type="checkbox"/> other

## 2. MECHANICAL SPECIFICATIONS

Module size	71.3mm(L)*54.9mm(W)* 5.9mm(H)
Viewing area	65.5mm(L)*40.0mm(W)
Dots size	0.42mm(L)*0.51mm(W)
Dots pitch	0.46mm(L)*0.56mm(W)
Weight	Approx.

### 3. Outline dimension

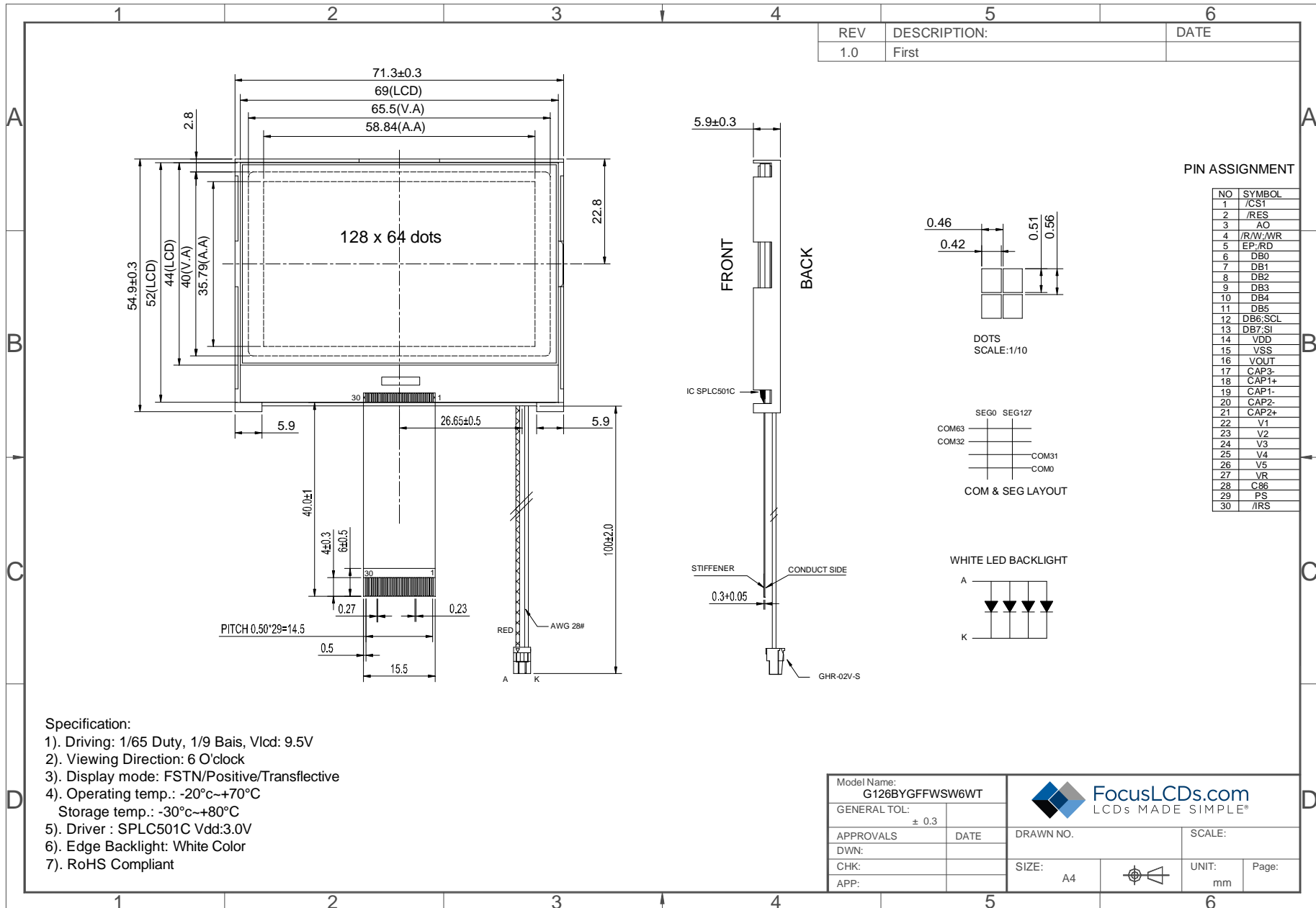

#### 4. Absolute maximum ratings

Item	Symbol	Min.	Typ.	Max.	Unit
Power voltage logic	$V_{DD}-V_{SS}$	0.3	-	3.6	V
Input voltage	$V_{IN}$	-0.3	-	$V_{DD}+0.3$	
Power supply for LCD	$V_0-V_{SS}$	-0.3	-	13.5	
Operating temperature range	$V_{OP}$	-20	-	+70	°C
Storage temperature range	$V_{ST}$	-30	-	+80	

#### 5. Block diagram

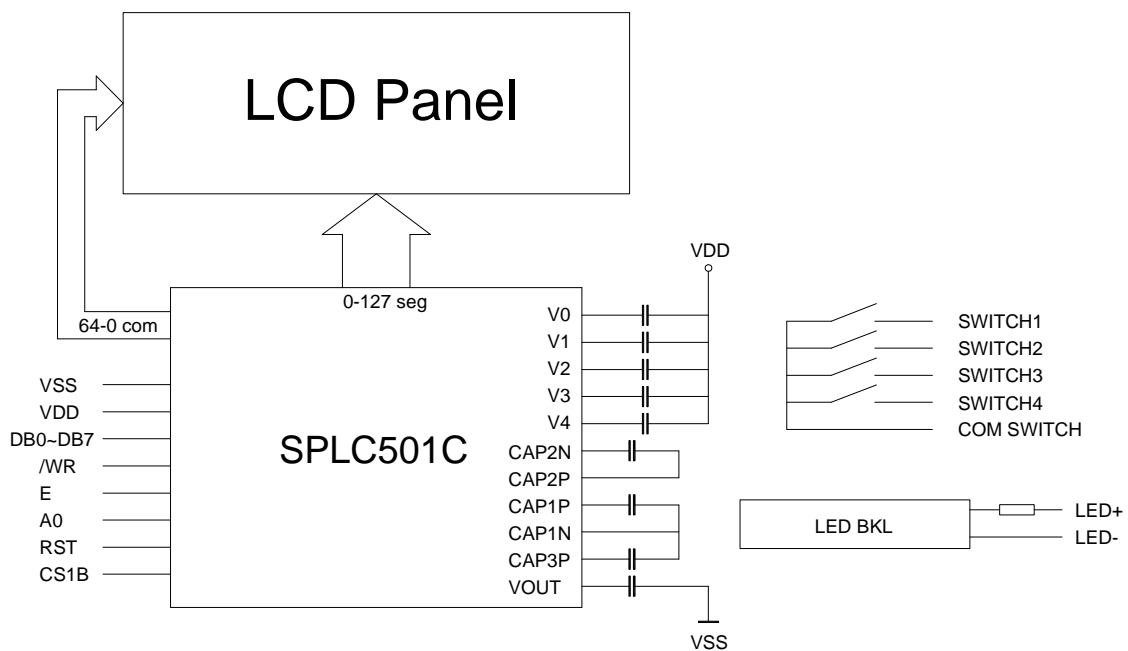

## 6. Interface pin description

Recommended Connector: FH52E-30S-0.5SH(99)

Pin no.	Symbol	External connection	Function
1	CS1	MPU	Chip select in serial interface low active
2	/RST	MPU	External reset PIN. Must be fixed to VDD low active.
3	A0	MPU	Select registers. 0: instruction; 1: data register
4	/WR	MPU	Read/write select signal
5	E	MPU	Operation (data read/write) enable signal
6~11	DB0~DB5	MPU	This is an 8-bit-directional data bus.
12	DB6;SCL	MPU	This is an 8-bit-directional data bus.
13	DB7;SI	MPU	This is an 8-bit-directional data bus.
14	V <sub>DD</sub>		Power supply for logic for LCM
15	V <sub>SS</sub>	Power supply	Signal ground for LCM
16	VOUT	O	DC/DC voltage converter. A capacitor is connected between this terminal and VSS
17	CAP3-	O	DC/DC voltage converter
18	CAP1+	O	DC/DC voltage converter
19	CAP1-	O	DC/DC voltage converter
20	CAP2-	O	DC/DC voltage converter
21	CAP2+	O	DC/DC voltage converter
22~26	V1~V5	Power supply	A multi-level power supply for the liquid crystal drive
27	VR		Output voltage regulator termina
28	C86		This is the MPU interface switch terminal
29	PS		This is the parallel data input/serial data input switch terminal
30	/IRS		the parallel data input/serial data input switch termina

## 7. Display data RAM

### 5.5. Display Data RAM

#### 5.5.1. Display data RAM

The display data RAM is a RAM that stores the dot data for the display. It has a 65 (8 page x 8 bit +1) x 132-bit structure. It is possible to access the desired bit by specifying the page address and the column address. Because, as is shown in Figure 3, the DB7 - 0 display data from the MPU corresponds to the liquid crystal display common direction, there are few constraints at the time of display data transfer when multiple SPLC501C chips are used. Therefore, display structures can be created easily and with a high degree of freedom.

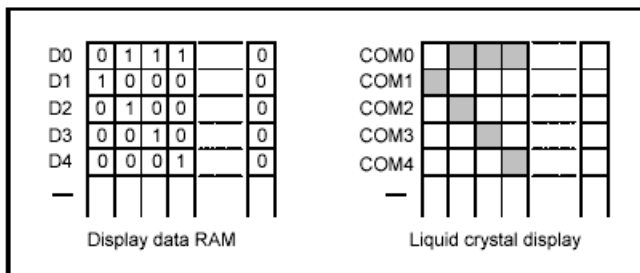

Figure 3

Moreover, reading from and writing to the display RAM in the MPU side is performed through the I/O buffer, which is an independent operation from signal reading for the liquid crystal driver. Consequently, even if the display data RAM is accessed asynchronously during liquid crystal display, it will not cause adverse effects on the display (such as flickering).

#### 5.5.2. The page address circuit

As shown in Figure 4, page address of the display data RAM is specified through the Page Address Set Command. The page address must be specified again when changing pages to perform access. Page address 8 (DB3, DB2, DB1, DB0 = 1, 0, 0, 0) is the page for the RAM region used only by the indicators, and only display data DB0 is used.

#### 5.5.3. The column addresses

As is shown in Figure 4, the display data RAM column address is specified by the Column Address Set command. The specified column address is incremented (+1) with each display data read/write command. This allows the MPU display data to be accessed continuously. Moreover, the increment of column addresses stops with 83H. Because the column address depends ON the page address, it is necessary to re-specify both the page address and the column address when moving, for example, from page 0 column 83H to page 1 column 00H. Furthermore, as is shown in Table 4, the ADC command (segment driver direction select command) can be used to reverse the

relationship between the display data RAM column address and the segment output. Because of this, the constraints on the IC layout when the LCD module is assembled can be minimized.

Table 4

SEG Output	SEG0	SEG131
ADC '0'	0 (H) →	Column Address → 83(H)
(DB0) '1'	83(H) ←	Column Address ← 0(H)

#### 5.5.4. The line address circuit

The line address circuit, as shown in Figure 4, specifies the line address relating to the COM output when the contents of the display data RAM are displayed. Using the display start line address set command, which is normally the top line of the display can be specified. This is the COM0 output when the common output mode is normal and the COM63 output for SPLC501C when the common output mode is reversed. The display area is a 65-line area for the SPLC501C from the display start line address. If the line addresses are changed dynamically using the display start line address set command, screen scrolling, page swapping, ... etc. can be performed.

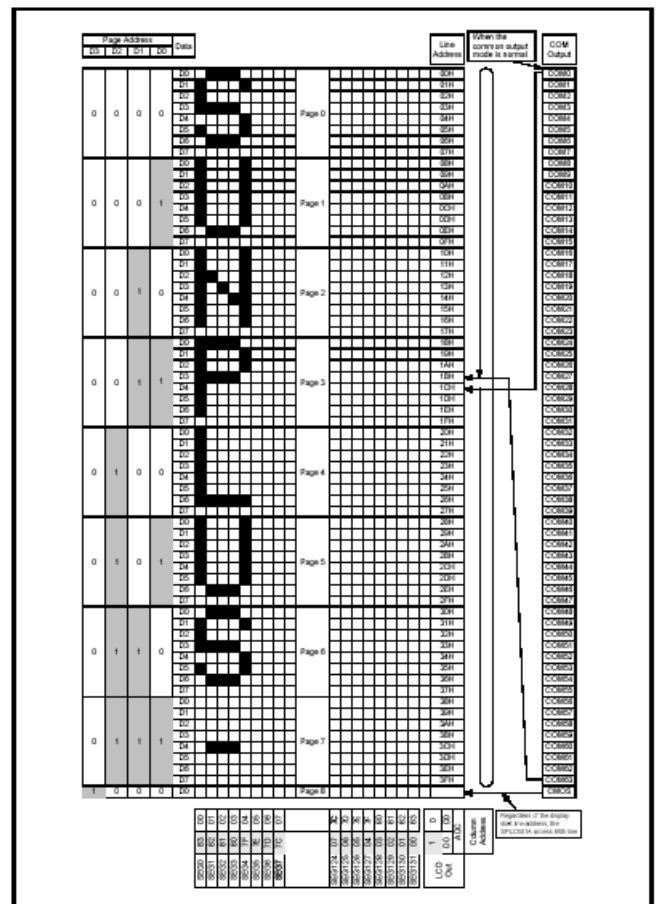

Figure 4

## 5.6. The Display Data Latch Circuit

The display data latch circuit temporarily stores the display data that is output to the liquid crystal driver circuit from the display data RAM. Because the display normal/reverse status, display ON/OFF status, and display all points ON/OFF commands control only the data within the latch, they do not change the data within the display data RAM itself.

## 5.7. The Oscillator Circuit

This is a CR-type oscillator that produces the display clock. The oscillator circuit is only enabled when MS = 'H' and CLS = 'H'. When CLS = 'L', the oscillation stops, and the display clock is input through the CL terminal.

## 5.8. The Common Output Status Select

In the SPLC501C chips, the COM output scan direction can be selected by the common output status select command (See Table 5.). Consequently, the constraints in IC layout at the time of LCD module assembly can be minimized.

**Table 5**

Status	COM Scan Direction
	SPLC501C
Normal	COM0→COM63
Reverse	COM63→COM0

## 5.9. Display Timing Generator Circuit

The display timing generator circuit generates the timing signal to the line address circuit and the display data latch circuit using the display clock. The display data is latched into the display data latch circuit synchronized with the display clock, and is output to the data driver output terminal. Reading to the display data liquid crystal driver circuits is completely independent of accesses to the display data RAM by the MPU. Consequently, even if the display data RAM is accessed asynchronously during liquid crystal display, there is absolutely no adverse effect (such as flickering) on the display. Moreover, the display timing generator circuit generates the common timing and the liquid crystal alternating current signal (FR) from the display clock. It generates a drive-wave form using a 2-frame alternating current drive method, as is shown in Figure 5, for the liquid crystal drive circuit.

# 8. Contrast adjust

## 5.11.2. The voltage regulator circuit

The step-up voltage generated at V<sub>OUT</sub> outputs the liquid crystal driver voltage V<sub>5</sub> through the voltage regulator circuit. Because the SPLC501C chips have an internal high-accuracy fixed voltage power supply with a 64-level electronic volume function and internal resistors for the V<sub>5</sub> voltage regulator, systems can be constructed without having to include high-accuracy voltage regulator circuit components. Moreover, in the SPLC501C, two types of thermal gradients have been prepared as V<sub>REG</sub> options: (1) approximately -0.05%/°C and (2) external input (supplied to the VRS terminal).

### 5.11.2.1. When the V<sub>5</sub> voltage regulator internal resistors are used

Through the use of the V<sub>5</sub> voltage regulator internal resistors and the electronic volume function, the liquid crystal power supply voltage, V<sub>5</sub>, can be controlled by commands alone (without adding any external resistors), making it possible to adjust the liquid crystal display brightness. The V<sub>5</sub> voltage can be calculated using equation A-1 over the range where |V<sub>5</sub>| < |V<sub>OUT</sub>|.

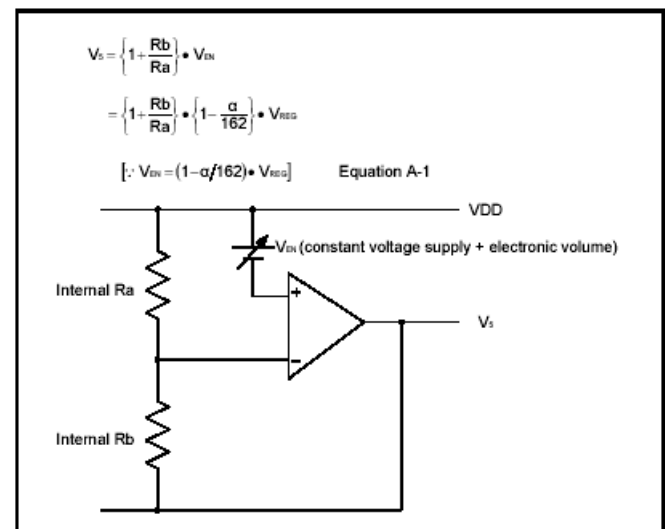

**Figure 8**

V<sub>REG</sub> is the IC-internal fixed voltage supply, and its voltage at T<sub>A</sub> = 25°C is as shown in Table 9.

**Table 9**

Equipment Type	Thermal Gradient	Units	VREG	Units
(1) Internal Power Supply	-0.05	[%/°C]	-2.1	[V]
(2) External Input	-	-	VRS	[V]

$\alpha$  is set to 1 level of 64 possible levels by the electronic volume function depending on the data set in the 6-bit electronic volume register. Table 10 shows the value for depending on the electronic volume register settings.

**Table 10**

DB5	DB4	DB3	DB2	DB1	DB0	$\alpha$
0	0	0	0	0	0	63
0	0	0	0	0	1	62
0	0	0	0	1	0	61
⋮	⋮	⋮	⋮	⋮	⋮	⋮
1	1	1	1	0	1	2
1	1	1	1	1	0	1
1	1	1	1	1	1	0

$R_b/R_a$  is the  $V_s$  voltage regulator internal resistor ratio, and can be set to 8 different levels through the  $V_s$  voltage regulator internal resistor ratio set command. The  $(1 + R_b/R_a)$  ratio assumes the values shown in Table 11 depending on the 3-bit data settings in the  $V_s$  voltage regulator internal resistor ratio register.

$V_s$  voltage regulator internal resistance ratio register value and  $(1 + R_b/R_a)$  ratio (Reference value)

**Table 11**

Register	SPLC501C	
	Equipment Type by Thermal Gradient [Units: %/°C]	
DB2 DB1 DB0	(1) -0.05	(2) VREG External Input
0 0 0	3.0	1.5
0 0 1	3.5	2.0
0 1 0	4.0	2.5
0 1 1	4.5	3.0
1 0 0	5.0	3.5
1 0 1	5.5	4.0
1 1 0	6.0	4.5
1 1 1	6.4	5.0

### 5.11.2.2. When an external resistance is used (i.e., The $V_s$ Voltage Regulator Internal Resistors are not used) (1)

The liquid crystal power supply voltage  $V_s$  can also be set without using the  $V_s$  voltage regulator internal resistors (IRS terminal = 'L') by adding resistors  $R_a'$  and  $R_b'$  between VDD and VR, and between VR and  $V_s$ , respectively. When this is done, the use of the electronic volume function makes it possible to adjust the brightness of the liquid crystal display by controlling the liquid crystal power supply voltage  $V_s$  through commands. In the range where  $|V_s| < |V_{OUT}|$ , the  $V_s$  voltage can be calculated using equation B-1 based on the external resistance,  $R_a'$  and  $R_b'$ .

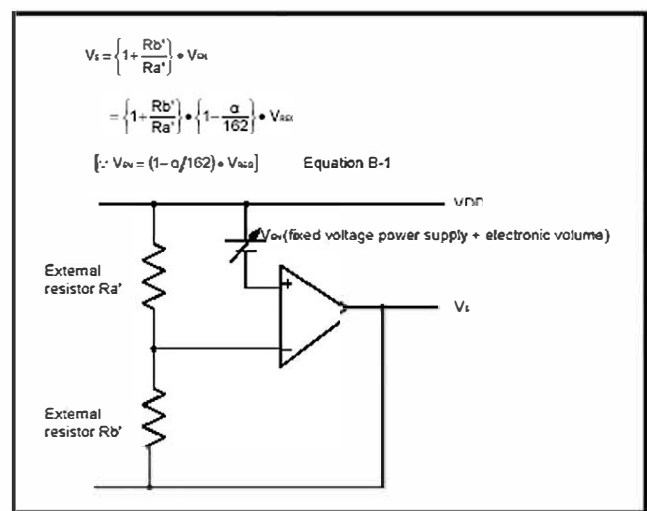
**Figure 9**

Setup example: When selecting  $T_A = 25^\circ\text{C}$  and  $V_s = -7.0\text{V}$  for an SPLC501C model where the temperature gradient =  $-0.05\%/^\circ\text{C}$ . When the central value of the electron volume register is (DB5, DB4, DB3, DB2, DB1, DB0) = (1, 0, 0, 0, 0, 0), then  $\alpha = 31$  and  $V_{REG} = -2.1\text{V}$ . According to equation B-1:

$$V_s = \left\{ 1 + \frac{R_b'}{R_a'} \right\} \cdot V_{EN}$$

$$-7.0\text{V} = \left\{ 1 + \frac{R_b'}{R_a'} \right\} \cdot \left\{ 1 - \frac{\alpha}{162} \right\} \cdot (-2.1) \quad \text{Equation B-2}$$

Moreover, when the value of the current running through  $R_a'$  and  $R_b'$  is set to  $5\mu\text{A}$ ,

$$R_a' + R_b' = 1.4\text{M}\Omega \quad \text{Equation B-3}$$



Consequently, by equations B-2 and B-3,

$$\frac{R_{b'}}{R_{a'}} = 3.12$$

$$R_{a'} = 340k\Omega$$

$$R_{b'} = 1060k\Omega$$

At this time, the  $V_s$  voltage variable range and notch width, based on the electron volume function, is as given in Table 12.

**Table 12**

$V_s$	Min.	Typ.	Max.	Units
Variable Range	-8.6 (63 levels)	-7.0 (central value)	-5.3 (0 level)	[V]
Notch width	-	52	-	[mV]

### 5.11.2.3. When external resistors are used (i.e. The $V_s$ Voltage Regulator Internal Resistors Are Not Used). (2)

When the external resistor described above are used, adding a variable resistor makes it possible to perform fine adjustments on  $R_{a'}$  and  $R_{b'}$ , to set the liquid crystal drive voltage  $V_s$ . In this case, the use of the electronic volume function makes it possible to control the liquid crystal power supply voltage  $V_s$  by commands to adjust the liquid crystal display brightness. In the range where  $|V_s| < |V_{out}|$  the  $V_s$  voltage can be calculated by equation C-1 below based on the  $R_1$  and  $R_2$  (variable resistor) and  $R_3$  settings, where  $R_2$  can be subjected to fine adjustments ( $\Delta R_2$ ).

$$V_s = \left\{ 1 + \frac{R_3 + R_2 - \Delta R_2}{R_1 + \Delta R_2} \right\} \cdot V_{EN}$$

$$= \left\{ 1 + \frac{R_3 + R_2 + \Delta R_2}{R_1 + \Delta R_2} \right\} \cdot \left\{ 1 - \frac{\alpha}{162} \right\} \cdot (V_{REG})$$

$$[\because V_{EN} = (1 - \alpha/162) \cdot V_{REG}] \quad \text{Equation C-1}$$

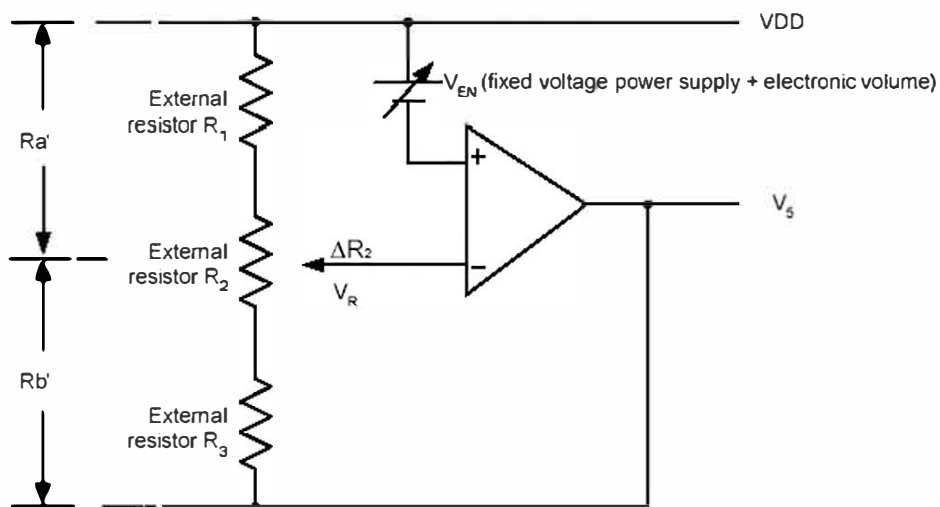

**Figure 10**

Setup example: When selecting  $T_A = 25^\circ\text{C}$  and  $V_S = -5.0\text{V}$  to  $-9.0\text{V}$  (using R2) for an SPLC501C model where the temperature gradient =  $-0.05\%/^\circ\text{C}$ .

When the central value for the electronic volume register is set at (DB5, DB4, DB3, DB2, DB1, DB0) = (1, 0, 0, 0, 0, 0),

$$\alpha = 31$$

$$V_{\text{REG}} = -2.1\text{V}$$

so, according to equation C-1, when  $\Delta R2 = 0\Omega$ , in order to make  $V_S = -9.0\text{V}$ ,

$$-9.0\text{V} = \left\{1 + \frac{R_3 + R_2}{R_1}\right\} \cdot \left\{1 - \frac{31}{162}\right\} \cdot (-2.1) \quad \text{Equation C-2}$$

When  $\Delta R2 = R2$ , in order to make  $V = -5.0\text{V}$ ,

$$-5.0\text{V} = \left\{1 + \frac{R_3}{R_1 + R_2}\right\} \cdot \left\{1 - \frac{31}{162}\right\} \cdot (-2.1) \quad \text{Equation C-3}$$

Moreover, when the current flowing VDD and  $V_S$  is set to  $5\mu\text{A}$ ,

$$R1 + R2 + R3 = 1.4\text{M}\Omega \quad \text{Equation C-4}$$

With this, according to equation C-2, C-3 and C-4,

$$R1 = 264\text{k}\Omega$$

$$R2 = 211\text{k}\Omega$$

$$R3 = 925\text{k}\Omega$$

At this time, the  $V_S$  voltage variable range and notch width based on the electron volume function is as shown in Table 13.

**Table 13**

$V_S$	Min.	Typ.	Max.	Units
Variable	-8.6	-7.0	-5.3	[V]
Range	(63 levels)	(central value)	(0 level)	
Notch width	-	53	-	[mV]

**Note1:** When the  $V_S$  voltage regulator internal resistors or the electronic volume function is used, it is necessary to at least set the voltage regulator circuit and the voltage follower circuit to an operating mode using the power control set commands. Moreover, it is necessary to provide a voltage from VOUT when the Booster circuit is OFF.

**Note2:** The VR terminal is enabled only when the  $V_S$  voltage regulator internal resistors are not used (i.e. the IRS terminal = 'L'). When the  $V_S$  voltage regulator internal resistors are used (i.e. when the IRS terminal = 'H'), the VR terminal is left open.

**Note3:** Because the input impedance of the VR terminal is high, it is necessary to take into consideration short leads, shield cables, etc. to handle noise.

### 5.11.3. The liquid crystal voltage generator circuit

The  $V_S$  voltage is produced by a resistive voltage divider within the IC, and can be produced at the  $V_1$ ,  $V_2$ ,  $V_3$ , and  $V_4$  voltage levels required for liquid crystal driving. Moreover, when the voltage follower changes the impedance, it provides  $V_1$ ,  $V_2$ ,  $V_3$  and  $V_4$  to the liquid crystal drive circuit. 1/9 bias or 1/7 bias for SPLC501C can be selected.

### 5.12. High Power Mode

The power supply circuit equipped in the SPLC501C chips has very low power consumption (normal mode: HPM = 'H'). However, for LCDs or panels with large loads, this low-power power supply may cause display quality to degrade. When this occurs, setting the HPM terminal to 'L' (high power mode) can improve the quality of the display. We recommend that the display be checked on actual equipment to determine whether or not to use this mode. Moreover, if the improvement to the display is inadequate even after high power mode has been set, it is necessary to add a liquid crystal drive power supply externally.

### 5.13. The Internal Power Supply Shutdown Command Sequence

The sequence shown in Figure 11 is recommended for shutting down the internal power supply. First place the power supply in power SAVER mode and then turn the power supply OFF.

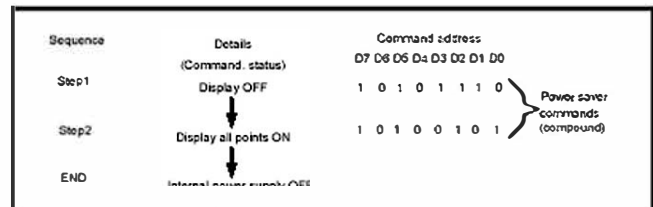

**Figure 11**

## 9. Optical characteristics

STN type display module (Ta=25°C, VDD=3.0V)

Item	Symbol	Condition	Min.	Typ.	Max.	Unit
Viewing angle	$\theta$	$C_r \geq 4$	-25	-	-	deg
	$\Phi$		-30	-	30	
Contrast ratio	$C_r$		-	2	-	-
Response time (rise)	$T_r$	-	-	120	150	ms
Response time (fall)	$T_r$	-	-	120	150	

FSTN type display module (Ta=25°C, VDD=3.0V)

Item	Symbol	Condition	Min.	Typ.	Max.	Unit
Viewing angle	$\theta$	$C_r \geq 2$	-60	-	35	deg
	$\Phi$		-40	-	40	
Contrast ratio	$C_r$		-	6	-	-
Response time (rise)	$T_r$	-	-	150	250	ms
Response time (fall)	$T_r$	-	-	150	250	

## 10. Electrical characteristics

DC characteristics

Parameter	Symbol	Conditions	Min.	Typ.	Max.	Unit
Supply voltage for LCD	$V_{DD}-V_0$	Ta =25°C	-	9.5	-	V
Input voltage	$V_{DD}$		-	3.0	-	
Supply current	$I_{DD}$	Ta=25°C, VDD=3.0V	-	0.25	0.45	mA
Input leakage current	$I_{LKG}$		-	-	1.0	uA
“H” level input voltage	$V_{IH}$		2.2	-	$V_{DD}$	V
“L” level input voltage	$V_{IL}$	Twice initial value or less	0	-	0.6	
“H” level output voltage	$V_{OH}$	LOH=-0.25mA	2.4	-	-	
“L” level output voltage	$V_{OL}$	LOH=1.6mA	-	-	0.4	
Backlight supply voltage	$V_F$		-	3.0	-	
Backlight supply current	$I_{LED}$	$V_F=3.0V$	-	80	-	mA

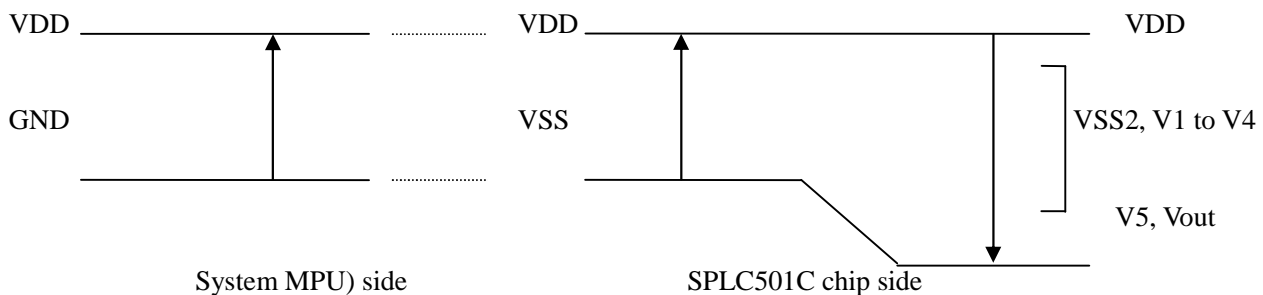

## 11. Timing Characteristics

System bus read/write characteristics 2 (for the 6800 series MPU)

(Ta=25°C, VDD=3.0V)

Item	Signal	Symbol	condition	Min.	Max.	Unit
Address hold time	A0	tAH6		0	-	ns
Address setup time		tAW6		0	-	
Address cycle time		tCYC6		240	-	
Enable L pulse width(write)	WR	tCCLW		80	-	
Enable H pulse width(write)		tCCHW		80	-	
Enable L pulse width(read)	RD	tCCLR		80	-	
Enable H pulse width(read)		tCCHR		140	-	
Write data setup time	DB0~DB7	tDS6		40	-	
Write address hold time		tDH6		0	-	
Read access time		tACC6	CL=100Pf	-	70	
Read output disable time		tOH6	CL=100Pf	5	50	

System Bus Read/Write Characteristics 2 (For the 6800 Series MPU)

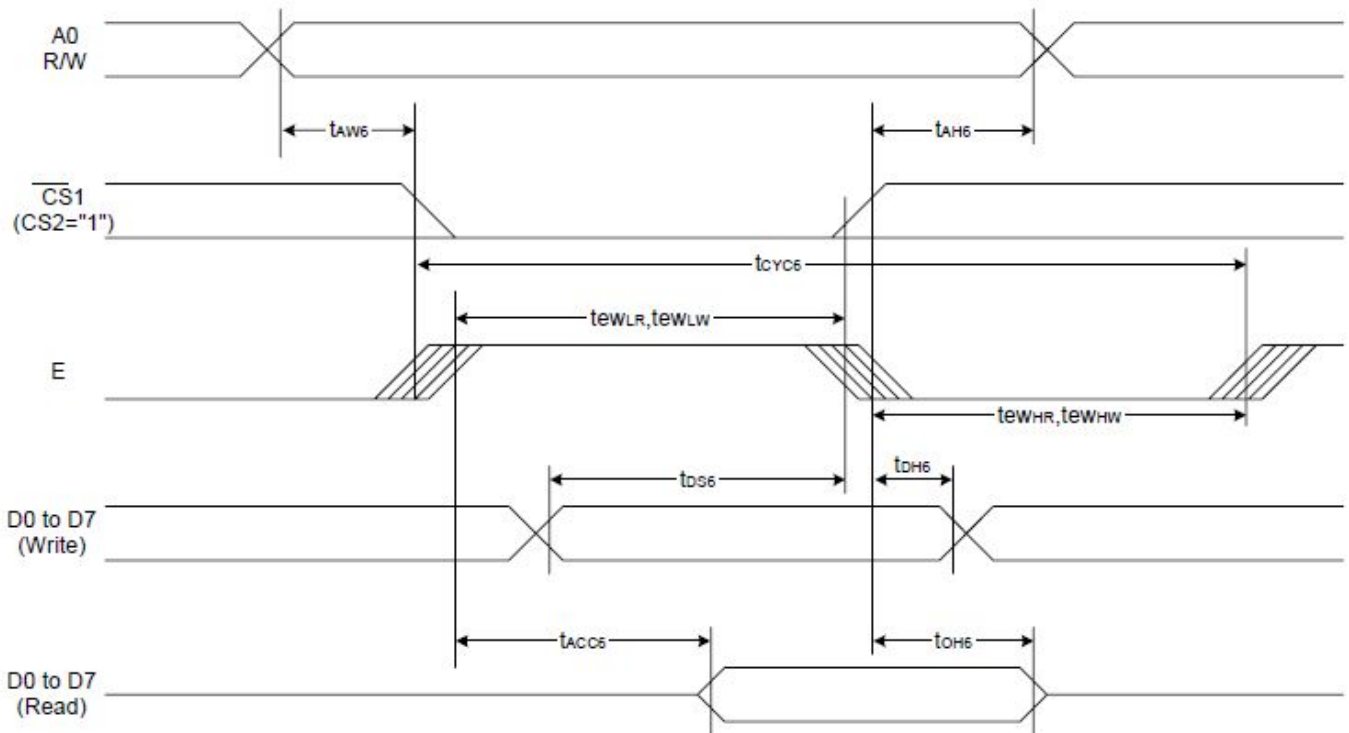

## 12. Instruction description

Command	Command Code								Function					
	AOP /WR	/RD	DB7 DB0	DB6	DB5	DB4	DB3	DB2		DB1				
1) Display ON/OFF	0	1	0	1	0	1	0	1	1	1	0	1	LCD display ON/OFF 0: OFF, 1: ON	
2) Display start line set	0	1	0	0	1	Display start address					Set the display RAM display start line address			
3) Page address set	0	1	0	1	0	1	1	Page address				Sets the display RAM page address		
4) Column address set upper bit	0	1	0	0	0	0	1	Most significant column address				Sets the most significant 4 bits of the display RAM column address		
Column address set Lower bit	0	1	0	0	0	0	0	Least significant column address				Sets the least significant 4 bits of the display RAM column address		
5) Status read	0	0	1	Status				0	0	0	0	0	Reads the status data	
6) Display data write	1	1	0	Write data								Writes the status RAM		
7) Display data read	1	0	1	Read data								Reads from the display RAM		
8) ADC select	0	1	0	1	0	1	0	0	0	0	0	0	1	Sets the display RAM address SEG output correspondence 0: normal, 1: reverse
9) Display normal/reverse	0	1	0	1	0	1	0	0	1	1	0	1	0	Sets the LCD display normal/reverse 0: normal, 1: reverse
10) Display all points ON/OFF	0	1	0	1	0	1	0	0	1	0	0	1	0	Display all points 0: normal display 1: all points ON
11) LCD bias set	0	1	0	1	0	1	0	0	0	1	0	1	0	Sets the LCD driver voltage bias ratio SPLC501C.....0: 1/9, 1: 1/7
12) Read/modify/write	0	1	0	1	1	1	0	0	0	0	0	0	0	Column address increment At write: +1 At read: 0
13) End	0	1	0	1	1	1	0	1	1	1	1	0	0	Clear read/modify/write
14) Reset	0	1	0	1	1	1	0	0	0	0	1	0	0	Internal reset
15) Common output mode select	0	1	0	1	1	0	0	0	0	*	*	*	1	Select COM output scan direction 0: normal direction 1: reverse direction
16) Power control set	0	1	0	0	0	1	0	1	Operating mode				Select internal power supply operating mode	
17) V5 voltage regulator internal resistor ratio set	0	1	0	0	0	1	0	0	Resistor ratio				Select internal resistor ratio (Rb/Ra) mode	
18) Electronic volume mode set	0	1	0	1	0	0	0	0	0	0	0	0	1	Set the V5 output voltage electronic volume register
Electronic volume register set	0	1	0	*	*	Electronic volume value								
19) Static indicator ON/OFF				1	0	1	0	1	1	0	0	0	1	0: OFF, 1: ON
Static indicator Register set				*	*	*	*	*	*	*	*	Mode	1	Set the flashing mode
20) Page Blink	0	1	0	1	1	0	1	0	1	0	1	0	1	P7-0: 1 – blinking page 0 – no blinking, normal display
Page selection	0	1	0	P7	P6	P5	P4	P3	P2	P1	P0			
21) Driving Mode set	0	1	0	1	1	0	1	0	0	1	0	0	0	Set the driving mode register Driving capability (D1, D0): (1,1)>(0,0)>(0,1)>(1,0)
Mode selection	0	1	0	D1	D0	0	0	0	0	0	0	0	0	
22) Power saver														Display OFF and display all points ON compound command

### 13. QUALITY SPECIFICATIONS

#### Standard of the product appearance test

Manner of appearance test: The inspection should be performed in using 20W x 2 fluorescent lamps. Distance between LCM and fluorescent lamps should be 100 cm or more. Distance between LCM and inspector eyes should be 30 cm or more.

Viewing direction for inspection is 45° from vertical against LCM.

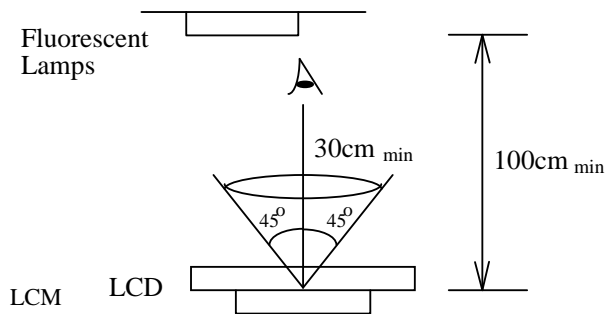

Definition of zone:

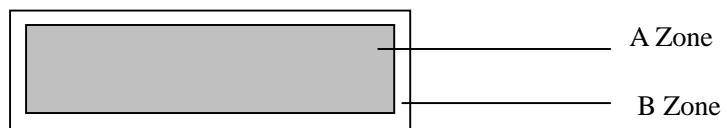

A Zone: Active display area (minimum viewing area).

B Zone: Non-active display area (outside viewing area).

## Specification of quality assurance

AQL inspection standard

Sampling method: MIL-STD-105E, Level II, single sampling

Defect classification **(Note: \* is not including)**

Classify	Item		Note	AQL
Major	Display state	Short or open circuit	1	0.65
		LC leakage		
		Flickering		
		No display		
		Wrong viewing direction		
		Contrast defect (dim, ghost)	2	
		Back-light	1,8	
	Non-display	Flat cable or pin reverse	10	
Wrong or missing component		11		
Minor	Display state	Background color deviation	2	1.0
		Black spot and dust	3	
		Line defect, Scratch	4	
		Rainbow	5	
		Chip	6	
		Pin hole	7	
	Polarizer	Protruded	12	
		Bubble and foreign material	3	
	Soldering	Poor connection	9	
	Wire	Poor connection	10	
	TAB	Position, Bonding strength	13	

**Note on defect classification**

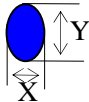
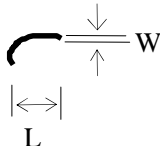
No.	Item	Criterion																				
1	Short or open circuit	Not allow																				
	LC leakage																					
	Flickering																					
	No display																					
	Wrong viewing direction																					
	Wrong Back-light																					
2	Contrast defect	Refer to approval sample																				
	Background color deviation																					
3	Point defect, Black spot, dust (including Polarizer)	 <table border="1" data-bbox="861 952 1300 1243"> <thead> <tr> <th>Point Size</th> <th>Acceptable Qty.</th> </tr> </thead> <tbody> <tr> <td><math>\phi \leq 0.10</math></td> <td>Disregard</td> </tr> <tr> <td><math>0.10 &lt; \phi \leq 0.20</math></td> <td>3</td> </tr> <tr> <td><math>0.20 &lt; \phi \leq 0.25</math></td> <td>2</td> </tr> <tr> <td><math>0.25 &lt; \phi \leq 0.30</math></td> <td>1</td> </tr> <tr> <td><math>\phi &gt; 0.30</math></td> <td>0</td> </tr> </tbody> </table> <p style="text-align: right;">Unit: mm</p>	Point Size	Acceptable Qty.	$\phi \leq 0.10$	Disregard	$0.10 < \phi \leq 0.20$	3	$0.20 < \phi \leq 0.25$	2	$0.25 < \phi \leq 0.30$	1	$\phi > 0.30$	0								
	Point Size		Acceptable Qty.																			
$\phi \leq 0.10$	Disregard																					
$0.10 < \phi \leq 0.20$	3																					
$0.20 < \phi \leq 0.25$	2																					
$0.25 < \phi \leq 0.30$	1																					
$\phi > 0.30$	0																					
	$\phi = (X+Y)/2$																					
4	Line defect, Scratch	 <table border="1" data-bbox="790 1377 1340 1646"> <thead> <tr> <th colspan="2">Line</th> <th>Acceptable Qty.</th> </tr> <tr> <th>L</th> <th>W</th> <th></th> </tr> </thead> <tbody> <tr> <td>---</td> <td><math>0.015 \geq W</math></td> <td>Disregard</td> </tr> <tr> <td><math>3.0 \geq L</math></td> <td><math>0.03 \geq W</math></td> <td rowspan="2">2</td> </tr> <tr> <td><math>2.0 \geq L</math></td> <td><math>0.05 \geq W</math></td> </tr> <tr> <td><math>1.0 \geq L</math></td> <td><math>0.1 &gt; W</math></td> <td>1</td> </tr> <tr> <td>---</td> <td><math>0.05 &lt; W</math></td> <td>Applied as point defect</td> </tr> </tbody> </table> <p style="text-align: right;">Unit: mm</p>	Line		Acceptable Qty.	L	W		---	$0.015 \geq W$	Disregard	$3.0 \geq L$	$0.03 \geq W$	2	$2.0 \geq L$	$0.05 \geq W$	$1.0 \geq L$	$0.1 > W$	1	---	$0.05 < W$	Applied as point defect
	Line		Acceptable Qty.																			
L	W																					
---	$0.015 \geq W$	Disregard																				
$3.0 \geq L$	$0.03 \geq W$	2																				
$2.0 \geq L$	$0.05 \geq W$																					
$1.0 \geq L$	$0.1 > W$	1																				
---	$0.05 < W$	Applied as point defect																				
5	Rainbow	Not more than two color changes across the viewing area.																				

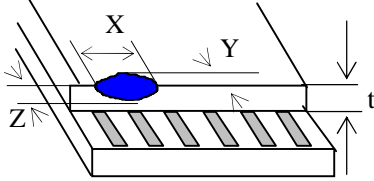
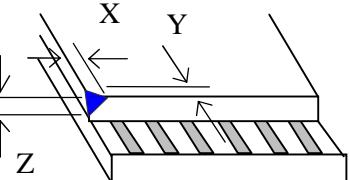
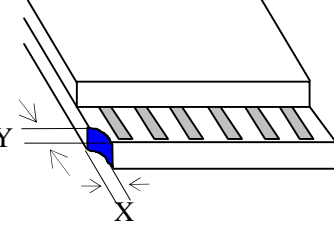
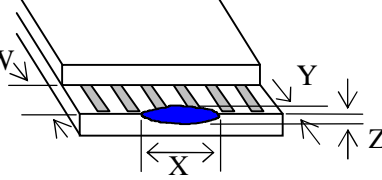
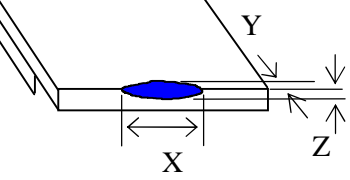

No	Item	Criterion																																	
6	Chip  Remark: X: Length direction Y: Short direction Z: Thickness direction t: Glass thickness W: Terminal Width	<div style="display: flex; flex-direction: column; align-items: flex-start;"> <div style="display: flex; align-items: center; margin-bottom: 20px;">  <div style="margin-left: 20px;"> <p>Acceptable criterion</p> <table border="1" style="border-collapse: collapse; text-align: center;"> <thead> <tr> <th>X</th> <th>Y</th> <th>Z</th> </tr> </thead> <tbody> <tr> <td><math>\leq 2</math></td> <td>0.5mm</td> <td><math>\leq t/2</math></td> </tr> </tbody> </table> </div> </div> <div style="display: flex; align-items: center; margin-bottom: 20px;">  <div style="margin-left: 20px;"> <p>Acceptable criterion</p> <table border="1" style="border-collapse: collapse; text-align: center;"> <thead> <tr> <th>X</th> <th>Y</th> <th>Z</th> </tr> </thead> <tbody> <tr> <td><math>\leq 2</math></td> <td>0.5mm</td> <td><math>\leq t</math></td> </tr> </tbody> </table> </div> </div> <div style="display: flex; align-items: center; margin-bottom: 20px;">  <div style="margin-left: 20px;"> <p>Acceptable criterion</p> <table border="1" style="border-collapse: collapse; text-align: center;"> <thead> <tr> <th>X</th> <th>Y</th> <th>Z</th> </tr> </thead> <tbody> <tr> <td><math>\leq 3</math></td> <td><math>\leq 2</math></td> <td><math>\leq t</math></td> </tr> <tr> <td colspan="2">shall not reach to ITO</td> <td></td> </tr> </tbody> </table> </div> </div> <div style="display: flex; align-items: center; margin-bottom: 20px;">  <div style="margin-left: 20px;"> <p>Acceptable criterion</p> <table border="1" style="border-collapse: collapse; text-align: center;"> <thead> <tr> <th>X</th> <th>Y</th> <th>Z</th> </tr> </thead> <tbody> <tr> <td>Disregard</td> <td><math>\leq 0.2</math></td> <td><math>\leq t</math></td> </tr> </tbody> </table> </div> </div> <div style="display: flex; align-items: center;">  <div style="margin-left: 20px;"> <p>Acceptable criterion</p> <table border="1" style="border-collapse: collapse; text-align: center;"> <thead> <tr> <th>X</th> <th>Y</th> <th>Z</th> </tr> </thead> <tbody> <tr> <td><math>\leq 5</math></td> <td><math>\leq 2</math></td> <td><math>\leq t/3</math></td> </tr> </tbody> </table> </div> </div> </div>	X	Y	Z	$\leq 2$	0.5mm	$\leq t/2$	X	Y	Z	$\leq 2$	0.5mm	$\leq t$	X	Y	Z	$\leq 3$	$\leq 2$	$\leq t$	shall not reach to ITO			X	Y	Z	Disregard	$\leq 0.2$	$\leq t$	X	Y	Z	$\leq 5$	$\leq 2$	$\leq t/3$
X	Y	Z																																	
$\leq 2$	0.5mm	$\leq t/2$																																	
X	Y	Z																																	
$\leq 2$	0.5mm	$\leq t$																																	
X	Y	Z																																	
$\leq 3$	$\leq 2$	$\leq t$																																	
shall not reach to ITO																																			
X	Y	Z																																	
Disregard	$\leq 0.2$	$\leq t$																																	
X	Y	Z																																	
$\leq 5$	$\leq 2$	$\leq t/3$																																	

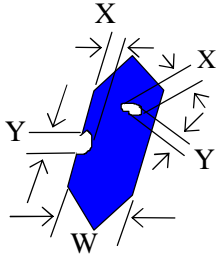
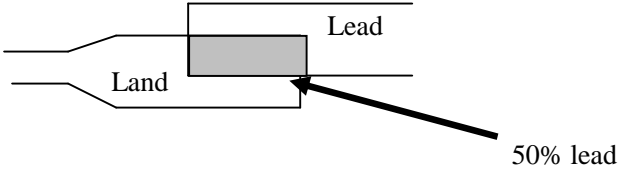
No.	Item	Criterion								
7	Segment pattern $W = \text{Segment width}$ $\phi = (X+Y)/2$	(1) Pin hole $\phi < 0.10\text{mm}$ is acceptable.  <table border="1" data-bbox="853 645 1316 817"> <thead> <tr> <th>Point Size</th> <th>Acceptable Qty</th> </tr> </thead> <tbody> <tr> <td><math>\phi \leq 1/4W</math></td> <td>Disregard</td> </tr> <tr> <td><math>1/4W &lt; \phi \leq 1/2W</math></td> <td>1</td> </tr> <tr> <td><math>\phi &gt; 1/2W</math></td> <td>0</td> </tr> </tbody> </table> <p style="text-align: right;">Unit: mm</p>	Point Size	Acceptable Qty	$\phi \leq 1/4W$	Disregard	$1/4W < \phi \leq 1/2W$	1	$\phi > 1/2W$	0
Point Size	Acceptable Qty									
$\phi \leq 1/4W$	Disregard									
$1/4W < \phi \leq 1/2W$	1									
$\phi > 1/2W$	0									
8	Back-light	(1) The color of backlight should correspond its specification. (2) Not allow flickering								
9	Soldering	(1) Not allow heavy dirty and solder ball on PCB. (The size of dirty refer to point and dust defect) (2) Over 50% of lead should be soldered on Land. 								
10	Wire	(1) Copper wire should not be rusted (2) Not allow crack on copper wire connection. (3) Not allow reversing the position of the flat cable. (4) Not allow exposed copper wire inside the flat cable.								
11*	PCB	(1) Not allow screw rust or damage. (2) Not allow missing or wrong putting of component.								

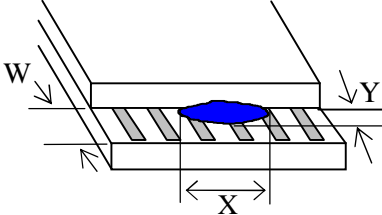
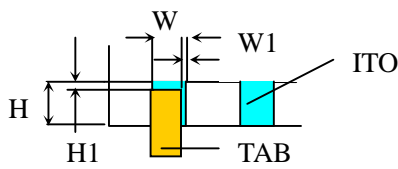
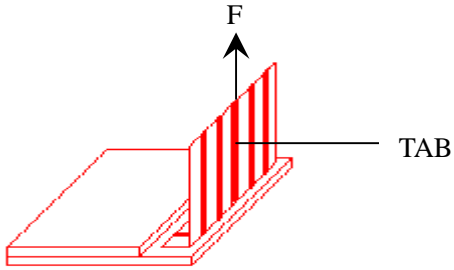
No	Item	Criterion
12	Protruded W: Terminal Width	 <p>Acceptable criteria:  <math>Y \leq 0.4</math></p>
13	TAB	<p>1. Position</p>  <div style="border: 1px solid black; padding: 5px; width: fit-content; margin-left: auto; margin-right: auto;"> <math>W1 \leq 1/3W</math>  <math>H1 \leq 1/3H</math> </div> <p>2. TAB bonding strength test</p>  <p> <math>P (=F/TAB \text{ bonding width}) \geq 650\text{gf/cm}</math> ,(speed rate: 1mm/min)            5pcs per SOA (shipment)         </p>
14	Total no. of acceptable Defect	<p>A. Zone</p> <p>Maximum 2 minor non-conformities per one unit.            Defect distance: each point to be separated over 10mm</p> <p>B. Zone</p> <p>It is acceptable when it is no trouble for quality and assembly in customer's end product.</p>

## Reliability of LCM

Reliability test condition:

Item	Condition	Time (hrs)	Assessment
High temp. Storage	80°C	48	No abnormalities in functions and appearance
High temp. Operating	70°C	48	
Low temp. Storage	-30°C	48	
Low temp. Operating	-20°C	48	
Humidity	40°C/ 90%RH	48	
Temp. Cycle	0°C ← 25°C → 50°C (30 min ← 5 min → 30min)	10cycles	

Recovery time should be 24 hours minimum. Moreover, functions, performance and appearance shall be free from remarkable deterioration within 50,000 hours under ordinary operating and storage conditions room temperature (20±8°C), normal humidity (below 65% RH), and in the area not exposed to direct sun light.

## Precaution for using LCD/LCM

LCD/LCM is assembled and adjusted with a high degree of precision. Do not attempt to make any alteration or modification. The followings should be noted.

### General Precautions:

1. LCD panel is made of glass. Avoid excessive mechanical shock or applying strong pressure onto the surface of display area.
2. The polarizer used on the display surface is easily scratched and damaged. Extreme care should be taken when handling. To clean dust or dirt off the display surface, wipe gently with cotton, or other soft material soaked with isopropyl alcohol, ethyl alcohol or trichlorotrifluoroethane, do not use water, ketone or aromatics and never scrub hard.
3. Do not tamper in any way with the tabs on the metal frame.
4. Do not make any modification on the PCB without consulting Focus LCDs
5. When mounting a LCM, make sure that the PCB is not under any stress such as bending or twisting. Elastomer contacts are very delicate and missing pixels could result from slight dislocation of any of the elements.
6. Avoid pressing on the metal bezel, otherwise the elastomer connector could be deformed and lose contact, resulting in missing pixels and also cause rainbow on the display.
7. Be careful not to touch or swallow liquid crystal that might leak from a damaged cell. Any liquid crystal adheres to skin or clothes, wash it off immediately with soap and water.

**Static Electricity Precautions:**

1. CMOS-LSI is used for the module circuit; therefore operators should be grounded whenever he/she comes into contact with the module.
2. Do not touch any of the conductive parts such as the LSI pads; the copper leads on the PCB and the interface terminals with any parts of the human body.
3. Do not touch the connection terminals of the display with bare hand; it will cause disconnection or defective insulation of terminals.
4. The modules should be kept in anti-static bags or other containers resistant to static for storage.
5. Only properly grounded soldering irons should be used.
6. If an electric screwdriver is used, it should be grounded and shielded to prevent sparks.
7. The normal static prevention measures should be observed for work clothes and working benches.
8. Since dry air is inductive to static, a relative humidity of 50-60% is recommended.

**Soldering Precautions:**

1. Soldering should be performed only on the I/O terminals.
2. Use soldering irons with proper grounding and no leakage.
3. Soldering temperature:  $280^{\circ}\text{C} \pm 10^{\circ}\text{C}$
4. Soldering time: 3 to 4 second.
5. Use lead free solder with no-clean flux.
6. If flux is used, the LCD surface should be protected to avoid spattering flux.
7. Flux residue should be removed.

**Operation Precautions:**

1. The viewing angle can be adjusted by varying the LCD driving voltage  $V_o$ .
2. Since applied DC voltage causes electro-chemical reactions, which deteriorate the display, the applied pulse waveform should be a symmetric waveform such that no DC component remains. Be sure to use the specified operating voltage.
3. Driving voltage should be kept within specified range; excess voltage will shorten display life.
4. Response time increases with decrease in temperature.
5. Display color may be affected at temperatures above its operational range.
6. Keep the temperature within the specified range usage and storage. Excessive temperature and humidity could cause polarization degradation, polarizer peel-off or generate bubbles.
7. For long-term storage over 40C is required, the relative humidity should be kept below 60%, and avoid direct sunlight.