



FOCUS LCDs
LCDs MADE SIMPLE®

Ph. 480-503-4295 | NOPP@FocusLCDs.com

TFT | OLED | CHARACTER | GRAPHIC | UWVD | SEGMENT | CUSTOM

Graphic Display Module

Part Number

G12864E-FTW-LW63

Overview:

- 128x64 Graphic LCD
- FSTN Positive, Gray
- 77.4x52.4 mm Module
- 80 or 68 MPU Interfaces
- White LED Backlight
- Transflective
- Wide Temp Range
- 3.0V
- LCD IC: AIP31565CR
- RoHS Compliant

Graphic LCD Features

Resolution: 128x64 Dots

Interface(s): 80 or 68 MPU

RoHS Compliant.

General Information Items	Specification	Unit	Note
	Main Panel		
Viewing Area (VA)	70.0 (H) x 40.0 (V)	mm	--
LCD Type	FSTN Positive	--	--
Viewing Angle	6:00	O'Clock	--
Polarizer	Transflective	--	--
Backlight Type	LED	--	--
Backlight Color	White	--	--
LCD IC	AIP31565CR	--	--
Drive Mode	1/64 Duty, 1/9 Bias	--	--
Operating Temperature	-20 to +70	°C	--
Storage Temperature	-30 to +80	°C	--

Mechanical Information

Item		Min.	Typ.	Max.	Unit	Note
Module Size	Horizontal (H)	--	77.40	--	mm	--
	Vertical (V)	--	52.40	--	mm	--
	Depth (D)	--	10.70	--	mm	--
Weight		--	36	--	g	Approximate

1. Outline Dimensions

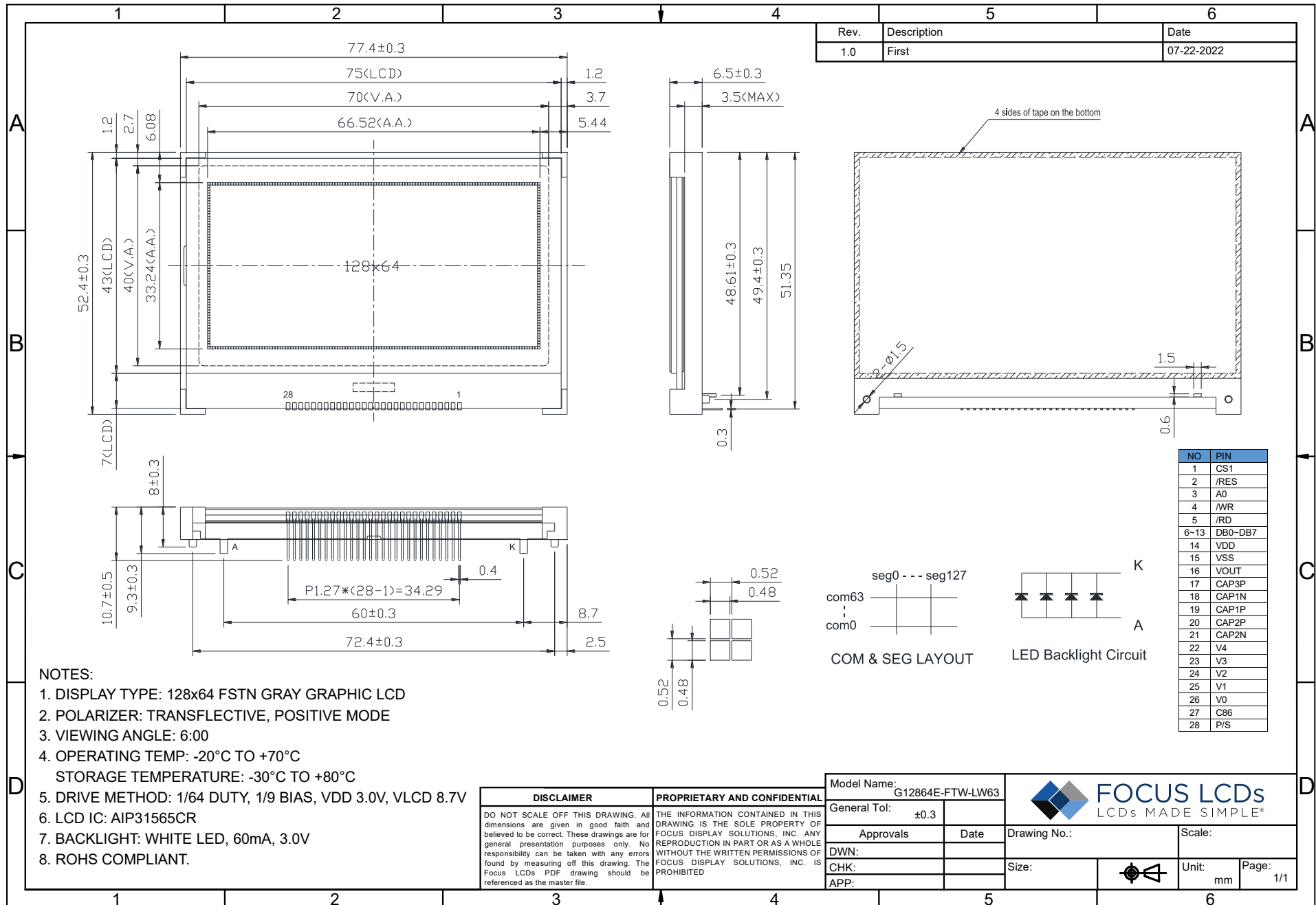

2. Input Terminal Pin Assignment

NO.	Symbol	Description	I/O
1	CS1	Chip select in serial interface low active.	MPU
2	/RES	External reset pin. Must be fixed to VDD low active.	MPU
3	A0	Select registers. 0: instruction; 1: data register.	MPU
4	/WR	Read/write select signal.	MPU
5	/RD	Operation (data read/write) enable signal.	MPU
6~13	DB0~DB7	This is an 8-bit-directional data bus.	MPU
14	VDD	Power supply for logic for LCM.	P
15	VSS	Signal ground for LCM.	P
16	VOUT	DC/DC voltage converter.	P
17	CAP3P	For voltage booster circuit. External capacitor is about 1uF~2.2uF.	P
18	CAP1N		
19	CAP1P		
20	CAP2P		
21	CAP2N		
22~26	V4~V0	Liquid crystal panel voltage regulator capacitor 1uF~4.7uF.	P
27	C86	This is the MPU interface switch terminal.	MPU
28	P/S	This is the parallel input/serial data input switch terminal.	MPU

P: Power, MPU: Microprocessor Unit

3. LCD Optical Characteristics

Item		Symbol	Condition	Min	Typ.	Max	Unit
Contrast Ratio		CR	--	2	5	--	--
Response Time	On	T _{on}	T _a =25°C	--	150	250	ms
	Off	T _{off}		--	200	300	ms
Viewing Angle	Hor.	Θ _L	Φ=270°, 9H	50	60	--	degree
		Θ _R	Φ=90°, 3H	50	60	--	
	Ver.	Θ _T	Φ=180°, 12H	30	40	--	
		Θ _B	Φ=0°, 6H	50	60	--	

4. Electrical Characteristics

4.1 Absolute Maximum Rating

Characteristics	Symbol	Min	Max	Unit
Supply Voltage	VDD	0.3	3.6	V
	Vout	-0.3	13.5	V
Operating Temperature	TOP	-20	+70	°C
Storage Temperature	TST	-30	+80	°C

NOTE: If the absolute maximum rating of the above parameters is exceeded, even momentarily, the quality of the product may be degraded. Absolute maximum ratings specify the values which the product may be physically damaged if exceeded. Be sure to use the product within the range of the absolute maximum ratings.

4.2 DC Electrical Characteristics

Characteristics	Symbol	Condition	Min	Typ.	Max	Unit	
LCD Driving Voltage	VLCD	--	8.4	8.7	9.0	V	
Supply Voltage	VDD	--	2.7	3.0	3.3	V	
Input Voltage	H Level	V _{IH}	--	0.8VDD	--	VDD	V
	L Level	V _{IL}	--	VSS	--	0.2VDD	V

Condition:

1. VDD = 3.0V
2. 1/64 Duty, 1/9 Bias

5. Module Function

5.1 Timing Characteristics

System Bus Read/Write Characteristics 1 (for the 8080 Series MPU)

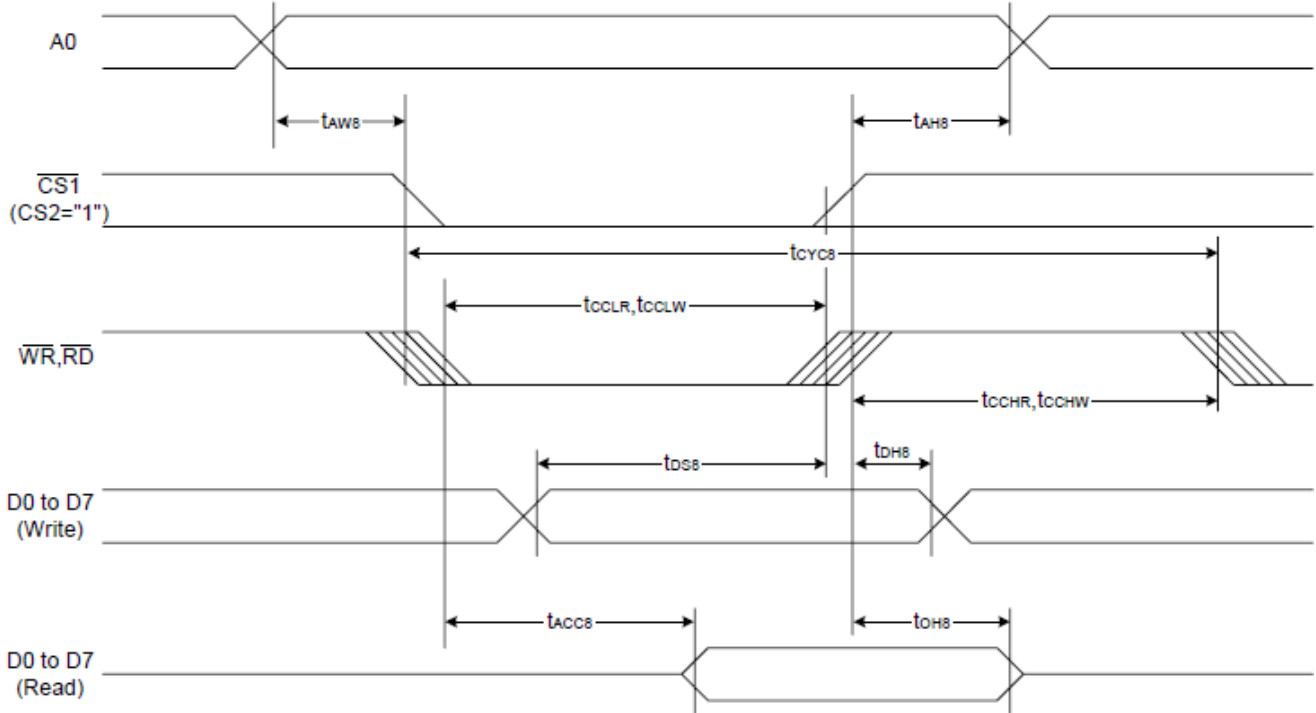

(VDD=3.0V, Ta=25°C)

Item	Signal	Symbol	Condition	Rating		Units
				Min.	Max.	
Address hold time	A0	t _{AH8}		0	-	ns
Address setup time		t _{AW8}		0	-	
Address cycle time		t _{CYC8}		240		
Enable L pulse width(write)	WR	t _{CCLW}		80	-	
Enable H pulse width(write)		t _{CCHW}		80	-	
Enable L pulse width(read)	RD	t _{CCLR}		140	-	
Enable H pulse width(read)		t _{CCHR}		80	-	
Write data setup time	DB0~DB7	t _{DS8}		40	-	
Write address hold time		t _{DH8}		0	-	
Read access time		t _{ACC8}	CL=100Pf	-	70	
Read output disable time		t _{OH8}	CL=100Pf	5	50	

System Bus Read/Write Characteristics 2 (for the 6080 Series MPU)

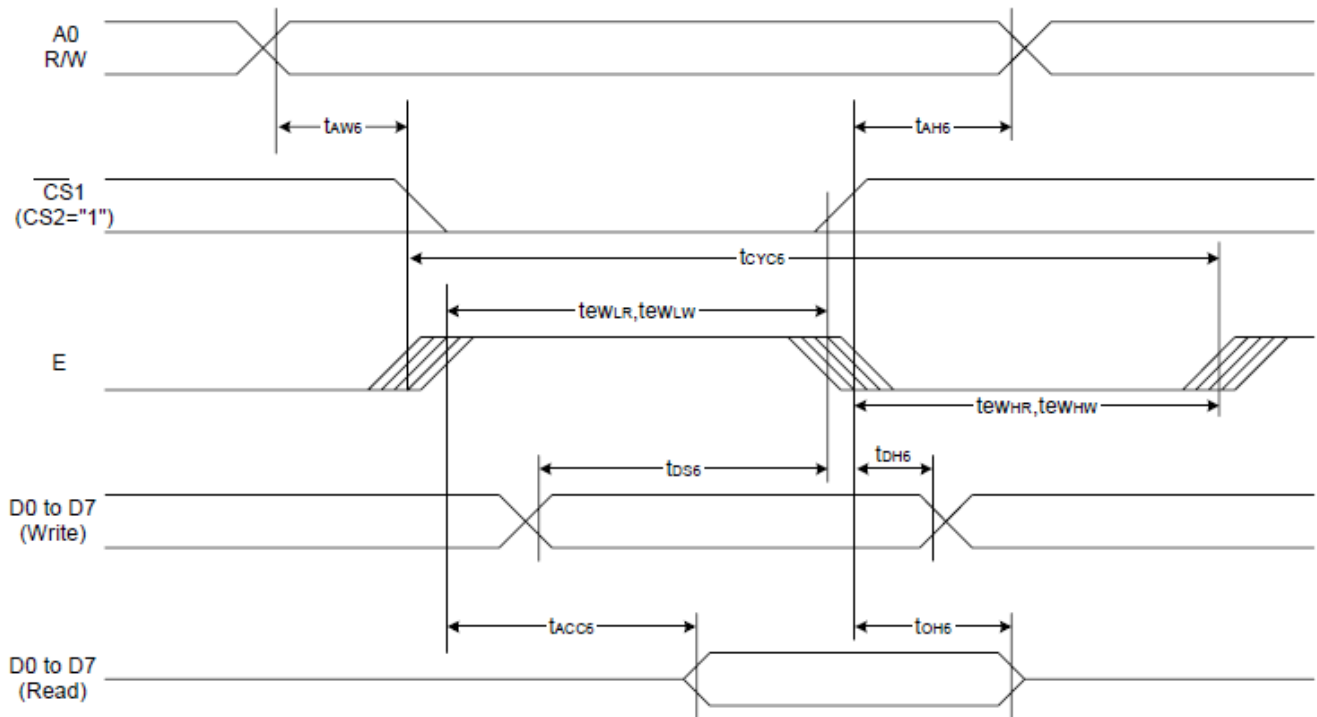

(VDD=3.0V, Ta=25°C)

Item	Signal	Symbol	Condition	Rating		Units
				Min.	Max.	
Address hold time	A0	t _{AH8}		0	-	ns
Address setup time		t _{AW8}		0	-	
Address cycle time		t _{CYC8}		240		
Enable L pulse width(write)	WR	t _{CCLW}		80	-	
Enable H pulse width(write)		t _{CCHW}		80	-	
Enable L pulse width(read)	RD	t _{CCLR}		140	-	
Enable H pulse width(read)		t _{CCHR}		80	-	
Write data setup time	DB0~DB7	t _{DS8}		40	-	
Write address hold time		t _{DH8}		0	-	
Read access time		t _{ACC8}	CL=100Pf	-	70	
Read output disable time		t _{OH8}	CL=100Pf	5	50	

5.2 LCM Application

Please see information on pages 21-24 of the data sheet for LCD controller AIP31565CR. The data sheet can be found here: <https://focuslcds.com/wp-content/uploads/Drivers/AiP31565CR.pdf>

5.3 Command Table

INSTRUCTION	A0	R/W	COMMAND BYTE								DESCRIPTION
			D7	D6	D5	D4	D3	D2	D1	D0	
Display ON/OFF	0	0	1	0	1	0	1	1	1	D	D=1, display ON D=0, display OFF
Set Start Line	0	0	0	1	S5	S4	S3	S2	S1	S0	Set display start line
Set Page Address	0	0	1	0	1	1	Y3	Y2	Y1	Y0	Set page address
Set Column	0	0	0	0	0	1	X7	X6	X5	X4	Set column address (MSB)
Address	0	0	0	0	0	0	X3	X2	X1	X0	Set column address (LSB)
Read Status	0	1	BUSY	MX	D	RST	0	0	0	0	Read IC Status
Write Data	1	0	D7	D6	D5	D4	D3	D2	D1	D0	Write display data to RAM
Read Data	1	1	D7	D6	D5	D4	D3	D2	D1	D0	Read display data from RAM
SEG Direction	0	0	1	0	1	0	0	0	0	MX	Set scan direction of SEG MX=1, reverse direction MX=0, normal direction
Inverse Display	0	0	1	0	1	0	0	1	1	INV	INV =1, inverse display INV =0, normal display
All Pixel ON	0	0	1	0	1	0	0	1	0	AP	AP=1, set all pixel ON AP=0, normal display
Bias Select	0	0	1	0	1	0	0	0	1	BS	Select bias setting 0=1/9; 1=1/7 (at 1/65 duty)
Read-modify-Write	0	0	1	1	1	0	0	0	0	0	Column address increment: Read:+0, Write:+1
END	0	0	1	1	1	0	1	1	1	0	Exit Read-modify-Write mode
RESET	0	0	1	1	1	0	0	0	1	0	Software reset
COM Direction	0	0	1	1	0	0	MY	-	-	-	Set output direction of COM MY=1, reverse direction MY=0, normal direction
Power Control	0	0	0	0	1	0	1	VB	VR	VF	Control built-in power circuit ON/OFF
Regulation Ratio	0	0	0	0	1	0	0	RR2	RR1	RR0	Select regulation resistor ratio
Set EV	0	0	1	0	0	0	0	0	0	1	Double command!! Set electronic volume (EV) level
	0	0	0	0	EV5	EV4	EV3	EV2	EV1	EVO	
Power Save	0	0	1	0	1	0	1	1	0	MD	MD=0, sleep mode MD=1, normal
Mode Set	0	0	0	0	0	0	0	0	0	0	
Power Save	0	0	Compound Command								Display OFF + All Pixel ON
Set Booster	0	0	1	1	1	1	1	0	0	0	Double command!! Set booster level: BL[1:0]=(0,0),x2,x3,x4 BL[1:0]=(0,1),x5 BL[1:0]=(1,1),x6
	0	0	0	0	0	0	0	0	BL1	BL0	
NOP	0	0	1	1	1	0	0	0	1	1	No operation
Test	0	0	1	1	1	1	-	-	-	-	Do NOT use. Reserved for testing.

5.4 Initialization Code

```
void lcminit(void)
{
    cs1=0;
    reset=0;
    shortdelay(1);
    reset=1;
    shortdelay(1);
    ctrl(0xa2); //LCD BIAS select 1/9 bias//
    ctrl(0xa0); //ADC select A0:SEG0->132 A1:SEG132->0//
    ctrl(0xc8); //SHL select c0:com0->63 c8:com63->0//

    ctrl(0x2e); //power control set vr on//
    shortdelay(1);
    ctrl(0x2f); //power control set vf on//
    ctrl(0x24); //regulator resistor select 20~27//
    ctrl(0x81); //reference voltage select mode//
    ctrl(0x2e); //reference voltage register 00~3F
    shortdelay(1);
    ctrl(0x40); //SET initial display line

}
```

6. Cautions and Handling Precautions

6.1 Handling and Operating the Module

1. When the module is assembled, it should be attached to the system firmly. Do not warp or twist the module during assembly work.
2. Protect the module from physical shock or any force. In addition to damage, this may cause improper operation or damage to the module and back-light unit.
3. Note that polarizer is very fragile and could be easily damaged. Do not press or scratch the surface.
4. Do not allow drops of water or chemicals to remain on the display surface. If you have the droplets for a long time, staining and discoloration may occur.
5. If the surface of the polarizer is dirty, clean it using some absorbent cotton or soft cloth.
6. The desirable cleaners are water, IPA (Isopropyl Alcohol) or Hexane. Do not use ketene type materials (ex. Acetone), Ethyl alcohol, Toluene, Ethyl acid or Methyl chloride. It might permanent damage to the polarizer due to chemical reaction.
7. If the liquid crystal material leaks from the panel, it should be kept away from the eyes or mouth. In case of contact with hands, legs, or clothes, it must be washed away thoroughly with soap.
8. Protect the module from static; it may cause damage to the CMOS ICs.
9. Use fingerstalls with soft gloves in order to keep display clean during the incoming inspection and assembly process.
10. Do not disassemble the module.
11. Protection film for polarizer on the module shall be slowly peeled off just before use so that the electrostatic charge can be minimized.
12. Pins of I/F connector shall not be touched directly with bare hands.
13. Do not connect, disconnect the module in the "Power ON" condition.
14. Power supply should always be turned on/off by the item Power On Sequence & Power Off Sequence.

6.2 Storage and Transportation

1. Do not leave the panel in high temperature, and high humidity for a long time. It is highly recommended to store the module with temperature from 0 to 35 °C and relative humidity of less than 70%.
2. Do not store the TFT-LCD module in direct sunlight.
3. The module shall be stored in a dark place. When storing the modules for a long time, be sure to adopt effective measures for protecting the modules from strong ultraviolet radiation, sunlight, or fluorescent light.
4. It is recommended that the modules should be stored under a condition where no condensation is allowed. Formation of dewdrops may cause an abnormal operation or a failure of the module. In particular, the greatest possible care should be taken to prevent any module from being operated where condensation has occurred inside.
5. This panel has its circuitry FPC on the bottom side and should be handled carefully in order not to be stressed.