



FOCUS LCDs

LCDs MADE SIMPLE®

Ph. 480-503-4295 | NOPP@FocusLCDs.com

TFT | OLED | GRAPHIC | CHARACTER | UWVD | SEGMENT | CUSTOM

Graphic OLED Module

Part Number

O25664B-GGS-TS3

Overview:

- 256x64 Graphic OLED
- White Grayscale Pixel Color
- Overall Size: 88.00mm x 27.80mm
- Parallel & Serial Interfaces
- -40C to 70C Operating Temperature
- 2.8V
- Controller: SSD1322
- RoHS Compliant

Graphic OLED Features:

Resolution: 256 x 64

Interface: 8-bit Parallel, 3/4-wire SPI

Controller: SSD1322

RoHS Compliant

General Information Items	Specification	Unit	Note
	Main Panel		
Viewing Area	78.78 x 21.18	mm	-
Pixel Color	Grayscale	-	-
Viewing Direction	Full	-	-
Voltage	2.8	V	-
Resolution	256x64	-	-
Controller IC	SSD1322	-	-
Interface	Parallel and Serial	-	-
Operating temperature	-40~+70	°C	-
Storage temperature	-40~+85	°C	-

Mechanical Information

Item		Min	Typ.	Max	Unit	Note
Module size	X (Width)	-	88.00	-	mm	-
	Y (Height)	-	27.80	-	mm	-
	Z (Depth)	-	-	2.00	mm	-

1. Outline Dimensions

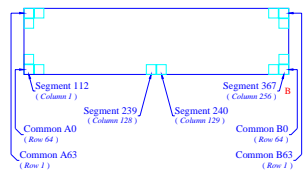
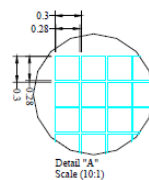
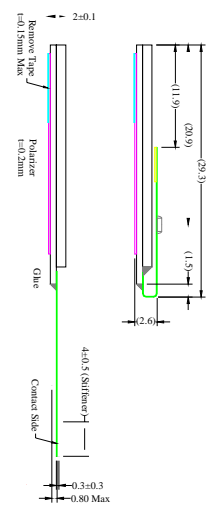
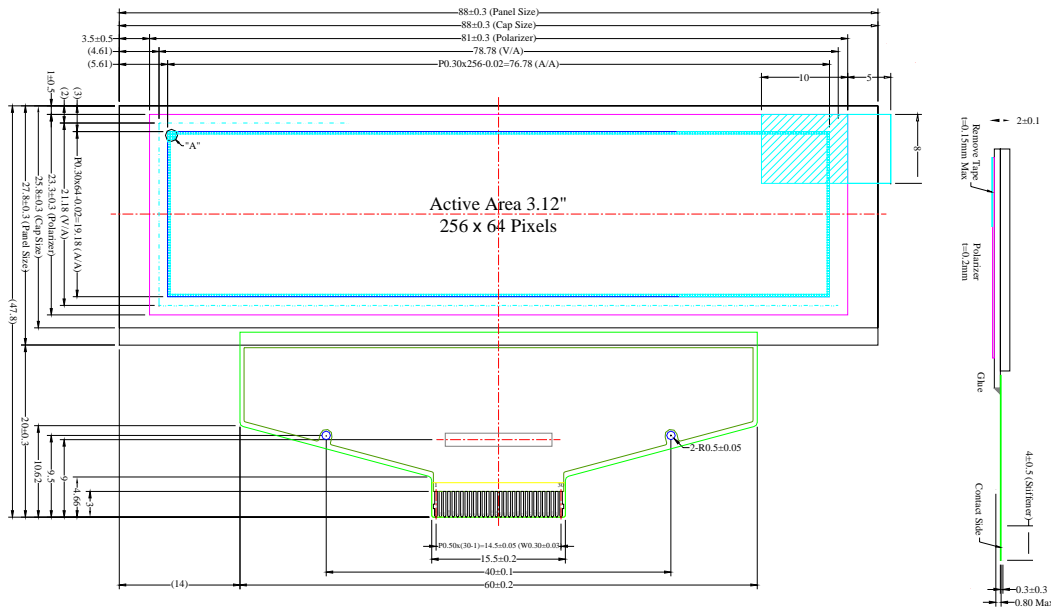

Pin	Symbol
1	N.C. (GND)
2	VSS
3	VCC
4	VCOMH
5	VLSS
6	D7
7	D6
8	D5
9	D4
10	D3
11	D2
12	D1
13	D0
14	E/RD#
15	R/W#
16	BS0
17	BS1
18	DC#
19	CS#
20	RES#
21	FR
22	IREP
23	N.C.
24	VDDIO
25	VDD
26	VCI
27	VSL
28	VLSS
29	VCC
30	N.C. (GND)

- Notes:
- 1.) Pixel Color: White Grayscale
 - 2.) OLED Type: Graphic
 - 4.) Temperature Range: Wide
 - 5.) Resolution: 256x64
 - 6.) Interface: 8-bit 68XX/80XX Parallel, 3/4 wire SPI
 - 7.) IC Controller: SSD1322



FOCUS LCDs
LCDs MADE SIMPLE®

		PARTS NO.	O25664B-GGS-TS3	
TOLERANCE UNLESS OTHERWISE SPECIFIED	X.X±0.3	Drawn		Unit
	X.XX±0.2	Checked		mm
Scale	1:1	Approve		Page 1/1

2. Input Terminal Pin Assignment

Recommended Connector: Hirose Part # FH19C-30S-0.5SH(10), 30 pin, 0.5mm pitch

NO.	Symbol	Description		
1	N.C.	No Connection / Reserved Pin		
2	VSS	Ground of Logic Circuit		
3	VCC	Power Supply for OEL Panel		
4	VCOMH	Voltage Output High Level for COM Signal		
5	VLSS	Ground of Logic Circuit		
6-13	D7-D0	Host Data Input/Output Bus		
14	E/RD#	Read/Write Enable or Read		
15	R/W#	Read/Write Select or Write		
16	BS0		BS0	BS1
		3-Wire Serial	1	0
		4-Wire Serial	0	0
17	BS1	8-bit 68xx Parallel	1	1
		8-bit 80xx Parallel	0	1
18	D/C#	Data/Command Control		
19	CS#	Chip Select		
20	RES#	Power Reset for Controller and Driver		
21	FR	Frame Frequency Triggering Signal		
22	IREF	Current Reference for Brightness Adjustment		
23	N.C.	Reserved Pin		
24	VDDIO	Power Supply for I/O Pin		
25	VDD	Power Supply for Core Logic Circuit		
26	VCI	Power Supply for Operation		
27	VSL	Voltage Output Low Level for SEG Signal		
28	VLSS	Ground of Analog Circuit		
29	VCC	Power Supply for OEL Panel		
30	N.C.	Reserved Pin (Supporting Pin)		

3. Optical Characteristics

Characteristic	Symbol	Condition	Min	Typ.	Max	Unit
Brightness	L_{br}	$V_{Cl} = 2.8V$ $V_{CC} = 12.0V$	60	80	-	cd/m ²
CIE (White)	X Y	-	0.25 0.27	0.29 0.31	0.33 0.35	-
Dark Room Contrast	CR	-	-	>10000:1	-	-
Viewing Angle	-	-	-	Full	-	degrees

4. DC Electrical Characteristics

Characteristics	Symbol	Conditions	Min	Typ.	Max	Unit
Supply Voltage for Operation	V_{Cl}	-	2.4	2.8	3.5	V
Supply Voltage for Logic	V_{DD}	-	2.4	2.5	2.6	V
Supply Voltage for I/O Pins	V_{DDIO}	-	1.65	1.8	V_{Cl}	V
Supply Voltage for Display	V_{CC}	-	11.5	12.0	12.5	V
High Level Input	V_{IH}	-	$0.8V_{DDIO}$	-	V_{DDIO}	V
Low Level Input	V_{IL}	-	0	-	$0.2V_{DDIO}$	V
High Level Output	V_{OH}	$I_{out}=100\mu A$	$0.9V_{DDIO}$	-	V_{DDIO}	V
Low Level Output	V_{OL}	$I_{out}=100\mu A$	0	-	$0.1V_{DDIO}$	V
Operating Current for V_{Cl}	I_{Cl}	-	-	180	300	μA
Operating Current for V_{CC}	I_{CC}	-	-	47.7	59.7	mA
Sleep Mode Current for V_{Cl}	$I_{Cl, SLEEP}$	-	-	20	100	μA
Sleep Mode Current for V_{CC}	$I_{CC, SLEEP}$	-	-	2	10	μA

NOTE: If the maximum rating of the above parameters is exceeded, even momentarily, the quality of the product may be degraded. The maximum ratings specify the values which the product may be physically damaged if exceeded. Be sure to use the product within the range of the specified parameters.

5. Timing Characteristics

5.1 68XX-Series MPU Parallel Interface Timing Characteristics

Parameter	Symbol	Min	Max	Unit
Clock Cycle Time	t_{cycle}	300	-	ns
Address Setup Time	t_{AS}	10	-	ns
Address Hold Time	t_{AH}	0	-	ns
Write Data Setup Time	t_{DSW}	40	-	ns
Write Data Hold Time	t_{DHW}	7	-	ns
Read Data Hold Time	t_{DHR}	20	-	ns
Output Disable Time	t_{OH}	-	70	ns
Access Time	t_{ACC}	-	140	ns
Chip Select Low Pulse Width (Read)	PW_{CSL}	120	-	ns
Chip Select Low Pulse Width (Write)		60		ns
Chip Select High Pulse Width (Read)	PW_{CSH}	60	-	ns
Chip Select High Pulse Width (Write)		60		ns
Rise Time	t_{r}	-	15	ns
Fall Time	t_{f}	-	15	ns

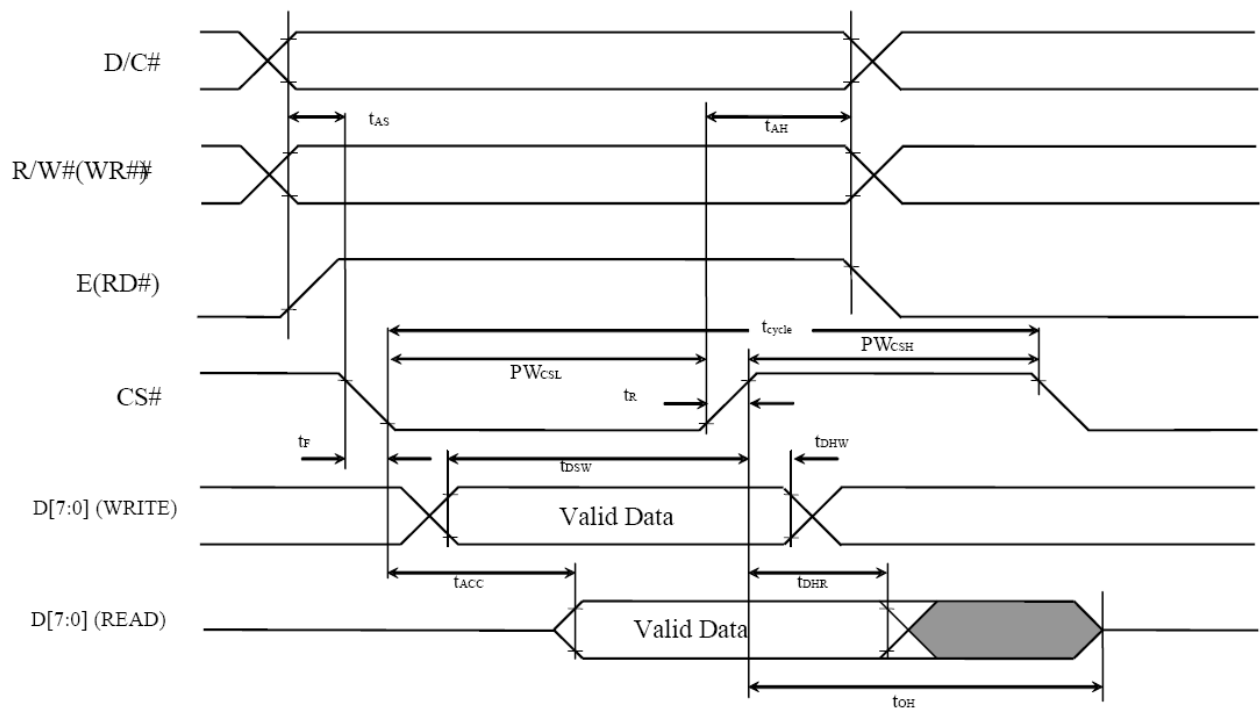

5.2 80XX-Series MPU Parallel Interface Timing Characteristics

Parameter	Symbol	Min	Max	Unit
Clock Cycle Time	t_{cycle}	300	-	ns
Address Setup Time	t_{AS}	10	-	ns
Address Hold Time	t_{AH}	0	-	ns
Write Data Setup Time	t_{DSW}	40	-	ns
Write Data Hold Time	t_{DHW}	7	-	ns
Read Data Hold Time	t_{DHR}	20	-	ns
Output Disable Time	t_{OH}	-	70	ns
Access Time	t_{ACC}	-	140	ns
Read Low Time	t_{PWLR}	150	-	ns
Write Low Time	t_{PWLW}	60	-	ns
Read High Time	t_{PWHR}	60	-	ns
Write High Time	t_{PWHW}	60	-	ns
Chip Select Setup Time	t_{CS}	0	-	ns
Chip Select Hold Time to Read Signal	t_{CSH}	0	-	ns
Chip Select Hold Time	t_{CSF}	20	-	ns
Rise Time	t_r	-	15	ns
Fall Time	t_f	-	15	ns

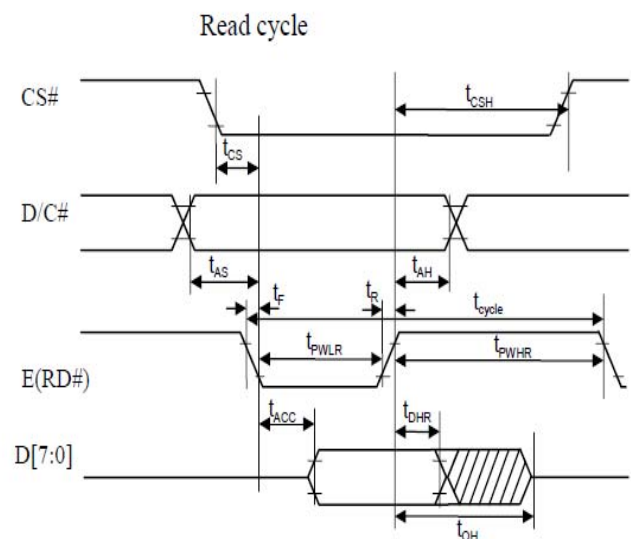
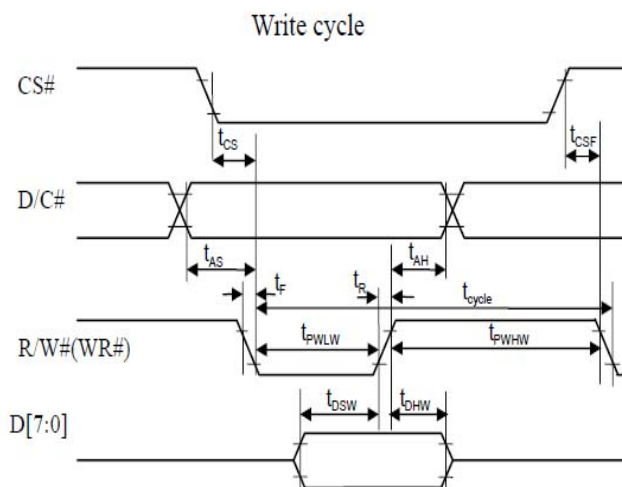

5.3 Serial Interface Timing Characteristics (4 wire Serial)

Parameter	Symbol	Min	Max	Unit
Clock Cycle Time	t_{cycle}	100	-	ns
Address Setup Time	t_{AS}	15	-	ns
Address Hold Time	t_{AH}	15	-	ns
Chip Select Setup Time	t_{CSS}	20	-	ns
Chip Select Hold Time	t_{CSH}	10	-	ns
Write Data Setup Time	t_{DSW}	15	-	ns
Write Data Hold Time	t_{DHW}	15	-	ns
Clock Low Time	t_{CLKL}	20	-	ns
Clock High Time	t_{CLKH}	20	-	ns
Rise Time	t_r	-	15	ns
Fall Time	t_f	-	15	ns

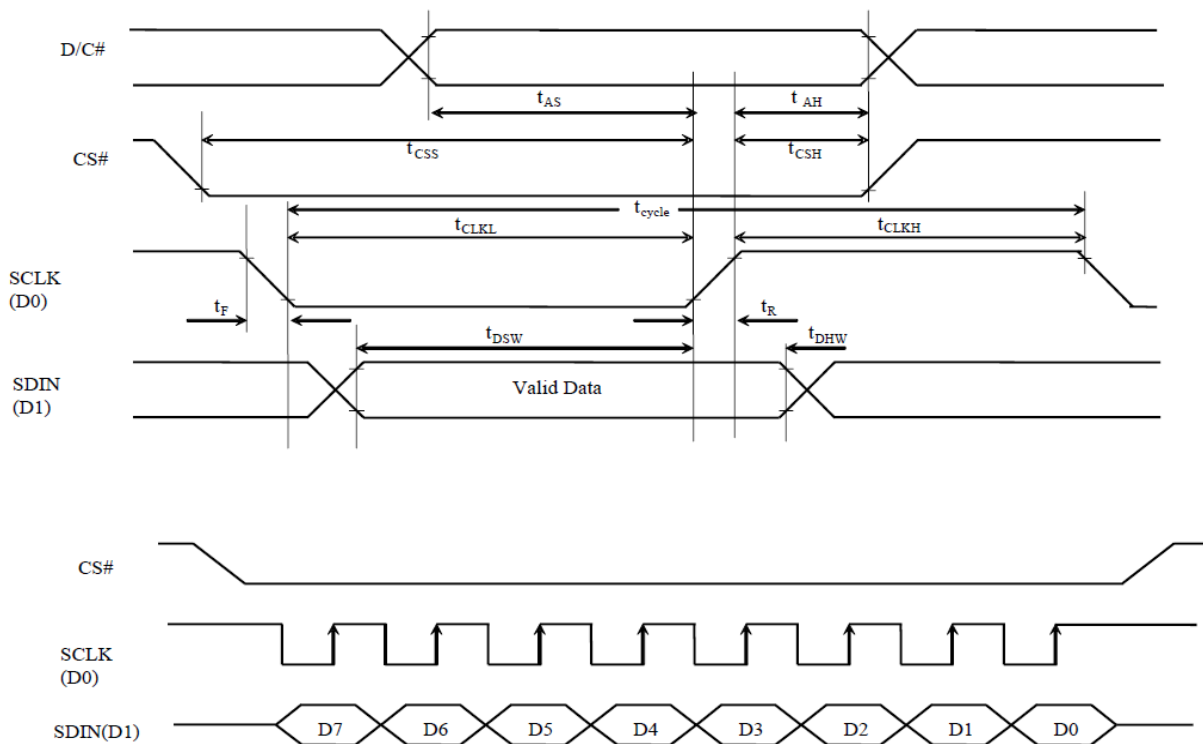

5.4 Serial Interface Timing Characteristics (3 wire Serial)

Parameter	Symbol	Min	Max	Unit
Clock Cycle Time	t_{cycle}	100	-	ns
Chip Select Setup Time	t_{CSS}	20	-	ns
Chip Select Hold Time	t_{CSH}	10	-	ns
Write Data Setup Time	t_{DSW}	15	-	ns
Write Data Hold Time	t_{DHW}	15	-	ns
Clock Low Time	t_{CLKL}	20	-	ns
Clock High Time	t_{CLKH}	20	-	ns
Rise Time	t_{R}	-	15	ns
Fall Time	t_{F}	-	15	ns

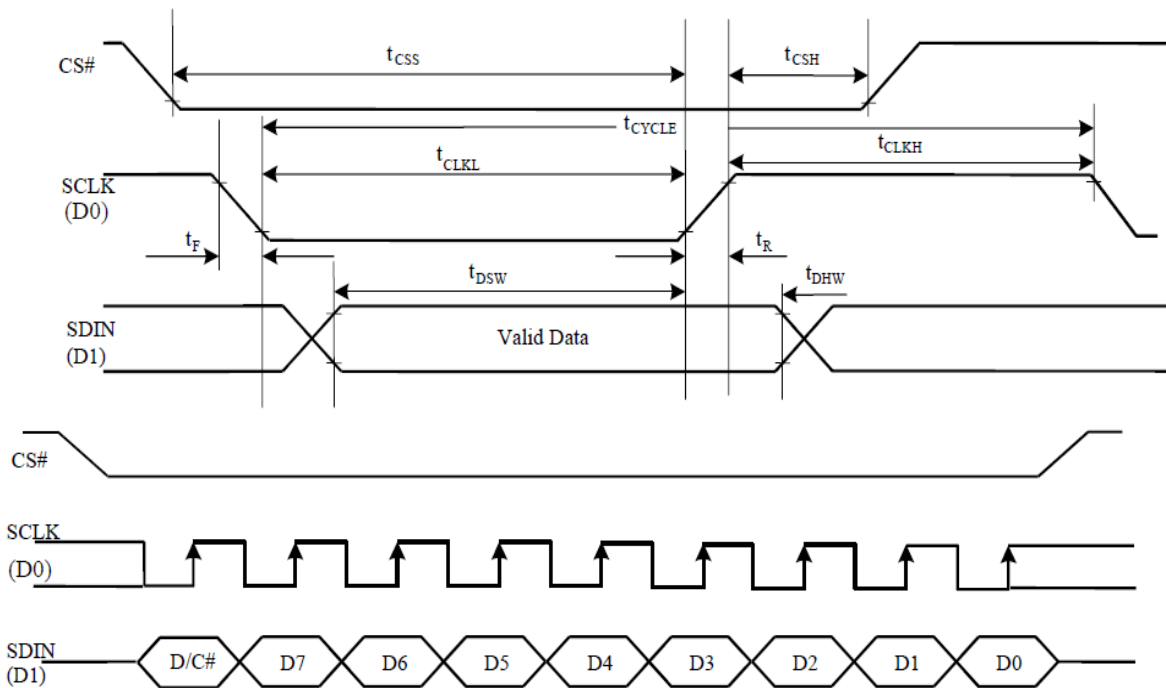

6. Cautions and Handling Precautions

6.1 Handling and Operating the Module

1. When the module is assembled, it should be attached to the system firmly. Do not warp or twist the module during assembly work.
2. Protect the module from physical shock or any force. In addition to damage, this may cause improper operation or damage to the module and back-light unit.
3. Note that polarizer is very fragile and could be easily damaged. Do not press or scratch the surface.
4. Do not allow drops of water or chemicals to remain on the display surface. If you have the droplets for a long time, staining and discoloration may occur.
5. If the surface of the polarizer is dirty, clean it using some absorbent cotton or soft cloth.
6. The desirable cleaners are water, IPA (Isopropyl Alcohol) or Hexane. Do not use ketene type materials (ex. Acetone), Ethyl alcohol, Toluene, Ethyl acid or Methyl chloride. It might permanent damage to the polarizer due to chemical reaction.
7. If the liquid crystal material leaks from the panel, it should be kept away from the eyes or mouth. In case of contact with hands, legs, or clothes, it must be washed away thoroughly with soap.
8. Protect the module from static, it may cause damage to the CMOS ICs.
9. Use finger-stalls with soft gloves in order to keep display clean during the incoming inspection and assembly process.
10. Do not disassemble the module.
11. Protection film for polarizer on the module shall be slowly peeled off just before use so that the electrostatic charge can be minimized.
12. Pins of I/F connector shall not be touched directly with bare hands.
13. Do not connect, disconnect the module in the "Power ON" condition.
14. Power supply should always be turned on/off by the item Power On Sequence & Power Off Sequence.

6.2 Storage and Transportation

1. Do not leave the panel in high temperature, and high humidity for a long time. It is highly recommended to store the module with temperature from 0 to 35 °C and relative humidity of less than 70%
2. Do not store the OLED module in direct sunlight.
3. The module shall be stored in a dark place. When storing the modules for a long time, be sure to adopt effective measures for protecting the modules from strong ultraviolet radiation, sunlight, or fluorescent light.
4. It is recommended that the modules should be stored under a condition where no condensation is allowed. Formation of dewdrops may cause an abnormal operation or a failure of the module. In particular, the greatest possible care should be taken to prevent any module from being operated where condensation has occurred inside.
5. This panel has its circuitry FPC on the bottom side and should be handled carefully in order not to be stressed.